



DTE Electric Company
One Energy Plaza, 1635 WCB
Detroit, MI 48226-1221

Estella R. Branson
estella.branson@dteenergy.com
(313) 235-6985

September 12, 2024

Lisa Felice
Acting Executive Secretary
Michigan Public Service Commission
7109 West Saginaw Highway
Lansing, MI 48917

RE: In the matter of the Application of **DTE ELECTRIC COMPANY** for authority to increase its rates, amend its rate schedules and rules governing the distribution and supply of electric energy, and for miscellaneous accounting authority
MPSC Case No. U-21534

Dear Ms. Felice:

The following is attached for paperless electronic filing:

Official Exhibits of the DTE Electric Company admitted into the record on September 4-6, 2024 and September 9-10, 2024:

Exhibit A-23, Schedules M9 thru M14

If you have any questions or concerns with this filing, please contact me at the above referenced number.

Respectfully submitted,

Estella R. Branson
Senior Paralegal

Enclosure

WOOD POLE MAINTENANCE SPECIFICATION

Engineering Standards Group

Table of Contents

Revision History 2

1 OBJECTIVE 3

2 SCOPE..... 3

3 INSPECTION PROCESS 3

 3.1 Site Preparation..... 3

 3.2 Confirm Esri data 3

 3.3 Visual Above-Ground Inspection 4

 3.4 Sound - Hammer Method..... 5

 3.5 Excavation 5

 3.5.1 Partial Excavation 5

 3.5.2 Full Excavation..... 6

 3.6 Decay Removal 6

 3.7 Boring 6

 3.7.1 Mandatory Boring 7

 3.7.2 Investigative Boring..... 7

 3.7.3 Steel Reinforced Pole Borings 7

4 EVALUATION 8

 4.1 Calculation..... 8

 4.2 Determining Reinforceable Candidates..... 8

 4.3 Determination of Pole Condition 9

5 REMEDIAL TREATMENT 10

 5.1 General Info..... 10

 5.2 External Groundline Treatment 10

 5.3 Internal Treatment 11

6 POLE RESTORATION 11

7 RESTORATION OF WORK SITE 12

 7.1 Plugs 12

 7.2 Back-Filling..... 12

 7.3 Clean-Up..... 12

8 POLE INSPECTION TAGGING 12

9 POLE REPLACEMENT 12

10 DELIVERABLES..... 13

11 PRIMARY SOURCES 13

APPENDIX 1 - EXAMPLES OF VISUAL ABOVE -GROUND DEFECTS 14

Change Date	Pole SME	Engineering Supervisor	Section	Note
7-9-19	DAM	NA	Sec.3.2	Cellon poles identification: pole stamp or pole tag
7-9-19	DAM	NA	Sec. 7.1	Plastic plug option added
7-9-19	DAM	NA	OH Spec 01-02-50.11	Restriction (d) high way crossing updated
7-9-19	DAM	NA	OH Spec 01-02-50.11	Restriction (h) removed
7-16-19	DAM	NA	Sec 2	Do not reinspect poles inspected in last 10 years
9-17-19	DAM	NA	Sec 3.5	50%, 75% fully excavation note
9-17-19	DAM	NA	Appendix 1	Split pole picture
9-17-19	DAM	NA	Sec 3.7	Mandatory Shell boring
11-12-19	DAM	NA	Sec 1	Except poles in substation and non DTE poles
11-12-19	DAM	NA	Sec 2	Poles inspected before 2019
11-12-19	DAM	NA	Sec 3.2	Pole tags vs. retreat tag
11-12-19	DAM	NA	Sec 3.2	"Cellon" treated poles by the Species/Treatment Code
11-12-19	DAM	NA	Sec 3.3	DTE does not repair above grade wood defects
11-12-19	DAM	NA	Sec 4.1	Raw pole data and results are provided and recorded by the contractor
11-12-19	DAM	NA	Sec 5.1	Treatment application restrictions
11-12-19	DAM	NA	Sec 5.4	Fumigants or void treatment above groundline for restorable rejects rule
2-21-20	CDW	NH	Sec 4	Replace the refence to "all four inspection points listed in Section 4" with "all the inspection points listed in Section 3"
2-21-20	CDW	NH	Sec 4	Updates to Raw Pole test data and Results (Calculated) pole test data
6-5-20	CDW	NH	Sec 5	Removed section 5.4 and put all internal treatments into section 5.3. Added Cobra Rods and Cobra Wrap
11-24-20	CDW	NH	Sec 3.3, Sec 3.73, Sec 4.3, Appendix 1	Added mechanical damages and boring direction for trussed poles. Added Trussed pole inspection criteria.
3-29-21	CDW	NH	Sec 3.3	Added non DTE poles and added poles previously inspected within 10 years.
12-7-21	CDW	NH	Sec 10	Added photos to be taken upon work completion.

1 OBJECTIVE

The objective of the Pole Inspection Program is to maintain the system mechanical integrity, for the safety of DTE employees, contractors and the public under the conditions specified by 2017 NESC (National Electric Safety Code) and recommended by Michigan Public Service Commission (MPSC). This objective is accomplished by inspecting and testing wood utility poles to identify poles that do not meet NESC requirements. These poles will be mechanically reinforced or replaced, based on criteria specified in this document.

The inspection criteria apply to all DTE poles, except poles located within substation fenced areas, including bare DTE poles (with no electrical components), and non-DTE poles with DTE hardware.

2 SCOPE

This specification is intended as a basis for the inspection and retreatment of wood poles. As a result of the Pole Inspection program, every pole meeting the in-service criteria will be inspected on a 10-year cycle. Poles inspected before 2019 should be re-inspected following this current inspection specification.

With few exceptions, poles less than 20 years old (10-19 years) will only be visually inspected, and poles 20 years and older will be visually inspected and tested.

3 INSPECTION PROCESS

3.1 Site Preparation

When work is to be done near a home, the property owner should be notified that a pole inspection is being performed by the pole inspector. Light brush and nests will be removed from around the pole to allow for proper excavation, inspection, and/or treatment unless permission for removal is denied by property owner. For excavation in lawns, sod grass areas, or flower gardens, care will be taken to leave the property as it was found.

Process Flow:

- If pole is found and site is accessible, continue with [Section 3.2 – Confirm Esri data](#)
- If a new pole, not recorded in Esri is found, continue with [Section 3.2 – Confirm Esri data](#)
- If site is not accessible, report to the DTE Project Manager to resolve the access issue.
- If the site is accessible but pole is not found at location, list pole as **Remove** and report to the DTE Project Manager.

3.2 Confirm Esri data

On all poles inspected, confirm the pole tags match Esri data. If there is a discrepancy between Esri data and the pole tag, use the pole tag and document the necessary changes. To confirm the pole data use information in this order: the pole's tags followed by pole's branding, followed by Esri data (except for the situation noted in bullet one below related to Cellon poles) or estimate based on field experience.

Note:

The following tags are to identify species treatment (R, RB, RE, RG), not to be confused with the pole tag

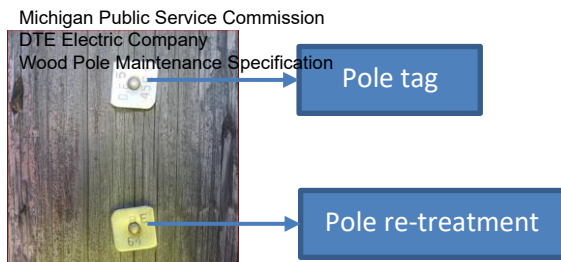

Process Flow:

- All Cellon treated poles are non-restorable rejects and are scheduled for replacement without any inspection; Identify “Cellon” treated poles by the Species/Treatment Code of GC/CG, NC/CN or WC/CW on the original pole marking tag or pole stamp. “Cellon” treated poles were set between 1968 and 1975; Do not use Esri data to determine Cellon treated poles; continue with [Section 9 – Pole Inspection Tagging](#).
- If pole is found and not Cellon treated, continue with [Section 3.3 – Visual Above-Ground Inspection](#)
- If the pole is a non-DTE pole with DTE infrastructure continue with [Section 3.3 – Visual Above-Ground Inspection](#)

3.3 Visual Above-Ground Inspection

A visual inspection shall be made from groundline to the top of the pole. Capture the general condition of the pole as well as the conditions of the pole attachments. For the list of pole attachments evaluated, refer to the Pole Top Maintenance Specification (PTM). Refer to [Appendix 1 – Examples of Visual Above -Ground Defects](#)

The following pole defects visible from the ground with a naked eye will be noted:

- Woodpecker holes that do not affect the integrity of the hardware
- Split tops with through bolts running perpendicular to the split
- Split tops that do not affect through bolts or hardware integrity
- Lightning and fire scars
- Extensive shell rot and checks
- Spur cuts that produced moderate damage
- Compression wood damage
- Mechanical Damages resulting in 1” depth or more of shell damage
- Cable poles: primary or secondary
- Detached or broken ground wire – need to notify DTE

DTE does not repair above ground wood defects by cutting tops, repairing woodpecker holes, installing split bolts or lowering hardware.

If the pole is an existing reinforced pole, a visual inspection of the existing reinforcer shall be performed. Things to be noted are as follows for data delivery:

- Reinforcer cap installed and intact
- Rusting on the reinforcer cap, reinforcers, or bands
- Mechanical damages to reinforcers or bands

Identify the age of the pole:

Assume poles are installed on Jan 1st based on the pole tag’s installation year, not the manufacturing branding. For example, a pole tagged with an install date of 1980 will have an assumed install date of Jan 1st, 1980. In this case, a test will be required if the pole was inspected in 1999 or later.

Missing Original Marking Tag

If a pole tag is missing, use information in this order: the pole's stamps followed by Esri data. Document the missing tag.

Process Flow:

- If the Original Marking Tag is missing, document for Data Delivery.
- Condition of existing reinforcer, document for Data Delivery.
- If non-DTE pole, visual inspection is the end of the Inspection process for that pole. We do not do physical testing on non-DTE poles.
- If the Visual Inspection does not result in a rejected pole and the pole **is less than** 20 years old, the pole is considered **acceptable** and no further testing is required; continue with [Section 4.3 – Determination of Pole Condition](#).
- If the Visual Inspection does not result in a rejected pole and the pole has been physically inspected within the last 10 years, the pole is considered acceptable and no further testing is required; continue with [Section 4.3 – Determination of Pole Condition](#).
- If the **Visual Inspection** does not result in a rejected pole and the pole **is** 20 or more years old based on the installation year, continue with [Section 3.4 - Sound-Hammer Method](#).
- If the pole fails the Visual Inspection, the pole is a **non-restorable rejected**; continue with [Section 8 - POLE INSPECTION TAGGING](#)
- Poles in non-testable locations and greater than 50 years old are **non-restorable rejects**; continue with [Section 8 - POLE INSPECTION TAGGING](#)

Examples of poles in non-testable locations:

- In water
- Wall around the pole
- Anything else that prevents an inspector from estimating the remaining pole strength

3.4 Sound - Hammer Method

The hammer method is used to identify potential areas of internal decay occurring above and below ground.

Poles shall be sounded with a hammer from as high as an inspector can reach to the groundline at various locations around the pole. Hammer marks should be visible to indicate that the area was sounded. Excavated poles should be sounded below ground. Internal decay below the groundline is common in cedar and yellow pine poles, and internal decay above groundline is common in Douglas fir and southern yellow pine poles.

Areas of concern that require investigative boring are identified by inconsistent sounds produced by the hammer tapping, excessive rebounding of the hammer, or areas where the hammer's head has penetrated the surface of the pole.

A sonic tool may be used as an alternative to the hammer method if approved by DTE.

Process Flow:

- After the Sound-Hammer Method is completed continue with [Section 3.5 - Excavation](#).

3.5 Excavation

3.5.1 Partial Excavation

Partial excavation is accomplished by digging on 2 sides of the pole 180 degrees apart, where decay is most likely to occur. The excavation is 8" wide and 8" deep for each side.

The portion of the pole exposed below groundline is cleaned with a wire brush or scraper and inspected for decay.

Note: Partial excavation will be used when at least 50% of the pole can't be fully excavated.

Process Flow:

- If surface decay is observed and at least 50% of the pole can be fully excavated, continue with [Section 3.5.2 - Full Excavation](#).
- If surface decay is not observed or 50 % of the pole can't be excavated, continue with [Section 3.7 - Boring](#).

3.5.2 Full Excavation

When surface decay is observed during the partial excavation, poles are excavated around the entire circumference to a depth of 18". The excavation is recommended to be approximately 10" from the pole at ground level and 4" from the pole at 18" depth to provide adequate access for inspection. Poles installed on slopes shall be excavated to a minimum depth of 18" on the down slope side and 18" on the high side.

Note: Record if the pole is 50%, 75% or 100% fully excavated.

Process Flow:

- Continue with [Section 3.6 - Decay Removal](#).

3.6 Decay Removal

Loose and decayed wood shall be removed from 18" below groundline to 6" above groundline. Decayed wood shall be removed from the hole and surrounding ground and disposed of properly. Care should be taken not to remove good wood as this will reduce the strength of the pole. The pole will be scraped using a check scraper or wire brush to remove dirt from the treatment zone.

Process Flow:

- Continue with [Section 3.7 – Boring](#)

3.7 Boring

Boring is used to determine shell thickness and measure internal decay pockets.

Poles shall be bored at least once at the groundline (Mandatory Boring) followed by additional boring based on the findings from the Sound-Hammer Method.

Any equipment (e.g. drill bits, shell thickness gauge, etc.) that comes in contact with wood cuttings must be thoroughly cleaned before boring the next pole to be tested to avoid cross-contamination of poles.

All measurements listed below should be recorded for the pole strength calculation:

- shell thickness
- depth and width and height of pocket
- orientation of the pocket in regard to line of lead

The holes are recommended to be staggered and space around the pole in a spiral pattern, so they do not weaken the pole.

Unless there is a reason to do otherwise, re-inspection should use the original inspection holes for assessing decay and applying remedial treatment

3.7.1 Mandatory Boring

Drill one 3/8" diameter hole at the ground level at a 45-degree angle to a depth of the center line of the pole. A shell thickness indicator is used to detect and estimate the internal decay.

In addition to mandatory boring, shell boring is required in situations described below:

- If the full excavation is only 50 to 75%, perform the 2 Shell boring:
Shell boring on the side that was excavated and compare with the shavings from the boring performed on the side that was not excavated
- For poles in concrete perform the first shell boring on side most likely to have decay and the second shell boring opposite side.

Process Flow:

- If decay is suspected, continue with [Section 3.7.2 – Investigative Boring](#)

3.7.2 Investigative Boring

Additional points are drilled around the pole above and below the groundline until there is no sign of decay. Multiple bores should not be taken in the same plane.

Above Groundline Boring

Any area above groundline suspected of internal decay based on findings from the Sound-Hammer Method shall be bored a minimum of four times above grade to determine the extent of decay.

Below Groundline Boring

In areas where **internal decay** is suspected below groundline, a pole will be bored three times:

1. For the first hole, bore at the groundline level at 45 degrees, satisfying the bore in the Mandatory Boring Section.
2. For the second hole, bore to a depth of the center line of the pole at 180° from the first hole, 3" below groundline and at an angle of 30°.
3. For the third hole, bore above the first hole approximately at groundline, horizontal to it, and to a depth of the center line of the pole.

Process Flow: Continue with [Section 4.1 – Calculation](#)

3.7.3 Steel Reinforced Pole Borings

To ensure reinforced poles still have adequate shell thickness at the banding locations, borings shall be performed at the banding locations to determine remaining shell thickness.

Upper Banding Location

Boring shall be performed at 3 locations (120 degrees apart) on the pole between the two lowest bands in the upper group of bands.

Lower Banding Location

Boring shall be performed at 3 locations (120 degrees apart) on the pole between the two lowest bands in the lower group of bands.

Process Flow:

- Continue with [Section 4.1 – Calculation](#)

4 EVALUATION

4.1 Calculation

Data collected on any internal/external rot and exposed/enclosed pockets is used to calculate the Percent Remaining Strength of the pole. In addition, the Groundline Effective Circumference will be measured. This can be performed by hand calculations utilizing a reduced section modulus approach in reference to the line-of-lead or by utilizing a software that is specific to calculating percent remaining strength. DTE shall approve method of calculation prior to start of work.

The following information must be provided and recorded by the contractor for each pole tested then used to determine percent remaining pole strength:

Raw pole test data:

- Measured circumference at groundline
- Measured shell thickness at groundline
- Minimum measured pole circumference below groundline
- Measured external decay
- Measured internal decay: depth, width and height of pocket
- Orientation of the pocket in regards to line of lead

Results (calculation) pole test data:

- Groundline Effective Circumference
- Percent Remaining Pole Strength
- Groundline Condition of the Pole:
 - Acceptable
 - Restorable Rejects
 - Non-Restorable Rejects

Process Flow:

- For poles up to 65 FT tall with 67-100% of their original strength and a shell thickness greater than or equal to 2 inches, continue with [Section 4.3 – Determination of Pole Condition.](#)
- For poles up to 65 FT tall with 15-66% of their original strength and a shell thickness greater than or equal to 2 inches, continue with [Section 4.2 – Determining Reinforceable Candidates.](#)
- For poles 70 FT or taller with 75-100% of their original strength and a shell thickness greater than or equal to 2 inches, continue with [Section 4.3 – Determination of Pole Condition.](#)
- For poles 70 FT or taller with 15-74% of their original strength, continue with [Section 4.2 – Determining Reinforceable Candidates.](#)

4.2 Determining Reinforceable Candidates

After the initial inspection, the decision for the rejected poles to be restored through a reinforcement system depends on the following criteria:

- Overhead Construction Standard specifications in Section 2 - Poles
- Poles went through the full excavation process and had the exterior groundline treatment applied
- Poles comply with current NESC requirements to meet the remaining % of the original strength and specified in [Section 4.1 - Calculation](#)
- Contractor process and procedure, approved by DTE (for example the 4-points of inspection)

Restorable reject poles are marked with a temporary yellow band.

Process Flow:

- Continue with [Section 4.3 - Determination of Pole Condition](#)

4.3 Determination of Pole Condition

Upon the results of the calculation, the following criteria is used to determine the state of the pole.

Process Flow:

Acceptable

- If the **Visual Inspection** does not result in a rejected pole and the pole is less than 20 years old, continue with [Section 8 – Pole Inspection Tagging](#).
- For poles with 100% strength, continue with [Section 7 – Restoration of Work Site](#).
- For poles up to 65 FT tall and with 67-99% original strength, continue with [Section 5 – Remedial Treatment](#).
- For poles 70 FT or taller and with 75- 99% original strength, continue with [Section 5 – Remedial Treatment](#).
- For existing reinforced poles with a minimum average of four inches (4”) of shell thickness at the upper banding location and one inch (1”) of shell thickness for double trusses or two inches (2”) of shell thickness for single trusses at the lower banding location, continue with [Section 5 – Remedial Treatment](#).

Restorable Reject

- For poles up to 65 FT tall with 15-66% original strength that pass all four inspection points listed in Section 4, continue with [Section 5.2 – External Groundline Treatment](#).
- For poles 70 FT or taller with 15-74% original strength that pass all four inspection points listed in Section 4, continue with [Section 5.2 – External Groundline Treatment](#).
- If reinforcing truss, truss cap, and/or banding has rust or mechanical damage, continue with [Section 5.3 – Internal Treatment](#).

Non-Restorable Reject

- Refer to OH Construction Spec 1-2-50.11 for a list of non-restorable reject, continue with [Section 7 – Restoration of Work Site](#).
- For poles failing the Visual Inspection, continue with [Section 8 – Pole Inspection Tagging](#).

- For Cellon treated poles, continue with [Section 8 – Pole Inspection Tagging](#).
- For poles in non-testable locations and greater than 50 years old, continue to [Section 8 – Pole Inspection Tagging](#).
- For poles with less than 15% of their original strength, continue with [Section 7 – Restoration of Work Site](#).
- For poles identified as potential restorable candidates but did not pass the four inspection points, continue with [Section 7 – Restoration of Work Site](#).
- If pole site conditions do not allow for an accurate ground strength measurement, continue with [Section 7 – Restoration of Work Site](#)
- If an exact measurement cannot be performed due to scattered decay, continue with [Section 7 – Restoration of work site](#).
- For poles with an average sound shell thickness less than one inch (1”), continue with [Section 7 – Restoration of Work Site](#).
- For existing reinforced poles with less than a minimum average of four inches (4”) of shell thickness at the upper banding location or one inch (1”) of shell thickness for double trusses or two inches (2”) of shell thickness for single trusses at the lower banding location, continue with [Section 7 – Restoration of Work Site](#).

5 REMEDIAL TREATMENT

5.1 General Info

All poles with less than 100% remaining strength are candidates for internal treatment, except poles that are going to be replaced. Treatment shall not be used on poles that do not have measurable evidence of decay, voids, or infestations, poles near water, sites with well water, school-ground, farmland or vegetable gardens. Treatments shall not be applied on non-restorable rejects poles. External treatment should be applied to all fully excavated poles.

Requests to deviate from the remedial treatments and materials listed below must be approved in writing by the DTE Standards engineer prior to purchase and application. Refer to Safety Data Sheets in the current contract for the approved chemicals.

To minimize the effect of repeat drilling on pole properties and unless there is a reason to do otherwise, re-inspection should use the original inspection holes for assessing decay and applying remedial treatment.

5.2 External Groundline Treatment

The scope of external ground line treatment is to protect outer shell of the wood pole at ground-line and reduce the loss of residual circumference due to decay.

All acceptable and restorable-reject poles that were fully excavated are treated with the external groundline treatment system, which shall be applied to the pole from 18" below groundline to 3" above groundline.

The external groundline treatment system is applied at the time of pole inspection

The approved external ground treatment system is the MP500-EXT preservative paste then wrapped with OsmoShield or Cobra Wrap.

5.3 Internal Treatment

The scope of internal treatment is to treat large voids caused by fungus or insect attack and to protect the heartwood and inner regions of the poles against future internal decay and insect.

The water-based preservative internal treatments are injected directly into the void and coat the surface to prevent further expansion of existing voids. The approved water-based preservative internal treatment is Hollow Heart CB, which contains copper and boron.

To protect against future internal decay and insects, a Fumigant should be applied. Fumigants should not be applied in holes that intersect seasoning checks because the fumigant will be lost; if the hole intersect a check plug the hole and drill another one. Do not apply fumigants in internal voids or rot-pockets; re-drill the hole in solid wood where the fumigant will gradually move through wood. The DTE approved fumigant is a granular formula, DuraFume II, which after application becomes volatile and move several feet from the point of application.

To treat both existing and future decay and insect attacking, treatment rods may be inserted into the pole below, at, and above the ground line. Do not use the rods if the above chemical treatments are applied at the time of inspection. The proper amount of treatment rods shall be installed based off the pole size. The approved treatment rod internal treatment is Cobra Rods, which contains copper, anhydrous disodium octaborate, and boric acid. Contractor must get approval from DTE to use the treatment rods.

If pole is an existing reinforced pole, internal treatments are to be applied at upper banding locations to extend the life span of the reinforcers.

All internal treatment holes are pugged at the time of treatment, per [Section 7.1 - Plugs](#)

All treatments must be applied per manufacture specifications and DTE specifications.

Process Flow:

Acceptable

- Apply remedial treatments if the pole meets the specifications outlined in Section 5, and continue with [Section 7 – Restoration of Work Site](#).

Restorable Reject

- If a pole is Restorable-Reject, only apply external groundline treatment at the time of pole Inspection, no internal treatment and continue with [Section 6 – Pole Restoration](#).

6 POLE RESTORATION

To restore the pole, refer to the contractor process and procedures, reviewed and approved by DTE.

Requests to deviate from the materials specified in contract must be approved in writing by the DTE Standards engineer prior to purchase and installation.

Process Flow:

- After the pole is reinforced, apply internal treatment per [Section 5.3 – Internal Treatment](#)
- After the internal treatment and the fumigant is applied continue with [Section 7 - Restoration of Work Site](#)

to [Section 8 – Pole Inspection Tagging](#).

7 RESTORATION OF WORK SITE

7.1 Plugs

Poles that are bored shall have all holes plugged with a tight-fitting plastic or pressure-treated (wolmanized) wood plug. Plugs shall be hammered into the holes until the plug is flush with the surface of the pole.

7.2 Back-Filling

After excavation and/or external groundline treatment, all poles will be solidly back-filled. The bottom half of the excavation will be back-filled and tamped completely around the pole by walking on the replaced excavation; the second half will be back-filled and tamped completely around the pole. The excess earth should be banked up to a maximum of 3" above normal ground level to allow for settlement. In grass areas, the sod shall be carefully placed around the pole. Rocks or stones should not be laid against the pole except where they serve to key the pole or where no other fill is available. Extreme care should be taken not to tear the moisture barrier while back-filling.

7.3 Clean-Up

The worksite shall be left as originally found. All chemical containers shall be disposed of in accordance with the product label and safety data sheet.

Process Flow:

- Continue with [Section 8 – Pole Inspection Tagging](#).

8 POLE INSPECTION TAGGING

Upon completion of the inspection at the designated pole, the inspector is to attach a tag to the pole indicating the year of the inspection and name of the company that performed the inspection. The tag is to be attached no higher than 6 ft above the ground and no lower than 4 ft above the ground. Based on the state of the pole at the time of inspection, the following visual identifiers are required:

- **Acceptable:** inspection tag and remedial treatment tag (if remedial treatment was applied)
- **Restorable Reject:** inspection tag, remedial treatment tag, temporary yellow band; After reinforcement the temporary yellow band is removed and replaced with the reinforced pole tag
- **Non-Restorable Reject:** inspection tag & red band

For proper tagging refer to OH Construction Spec Section 2

Note: Never remove any pole tags

Process Flow:

- Continue with [Section 10 – Deliverables](#).

9 POLE REPLACEMENT

Poles identified as rejects are replaced by DTE.

10 DELIVERABLES

Data is required to be delivered in a flat format compatible with DTE's data delivery specifications. Issues related to compatibility will be the contractor's responsibility. Photos are to be taken upon completion of work to show pole top to ground line once all work is complete encompassing any banding or reinforcement that has been completed at the work location.

11 PRIMARY SOURCES

1. 2017 NESC
2. RUS Bulletin 1730B-121 (approved August 13, 2013)
3. AWPAs Standard M13-07 Guidelines for a Pole Maintenance Program
4. Jeffery J. Morrell: Wood Pole Maintenance Manual, 2012 Edition, Oregon State University, Forest Research Laboratory

APPENDIX 1 - EXAMPLES OF VISUAL ABOVE -GROUND DEFECTS

The evaluation of pole top defects is an inherently subjective process due to the lack of a means of measurement. In addition, the inspection is made visually from the ground and can be hampered by the light/sky conditions, inclement weather, masking vegetation, etc. This document has been created in an effort to narrow the field evaluation subjectivity of pole top conditions and increase consistency between inspectors. It should be understood however, that the process remains limited. Pole owners are encouraged to further examine questionable defects from close proximity with the aid of a bucket truck or other means before proceeding with expensive pole replacement.

Note: This criterion reflects DTE's practice to not repair above ground wood defects by cutting tops, repairing woodpecker holes, installing split bolts, or lowering hardware

Light conditions have an impact on the inspection process, as seen in the picture below:



Poles with extensive shell rot or surface decay that affect the integrity of the pole is recommended for replacement.



DECAYED TOPS:

Poles with decay conditions that affect the integrity of hardware is recommended for replacement, regardless of ground line conditions.



DECAYED TOPS:

Poles with decayed tops that show evidence of crowning, daylight and/or decay close to through bolts or hardware is recommended for replacement, regardless of ground line conditions.

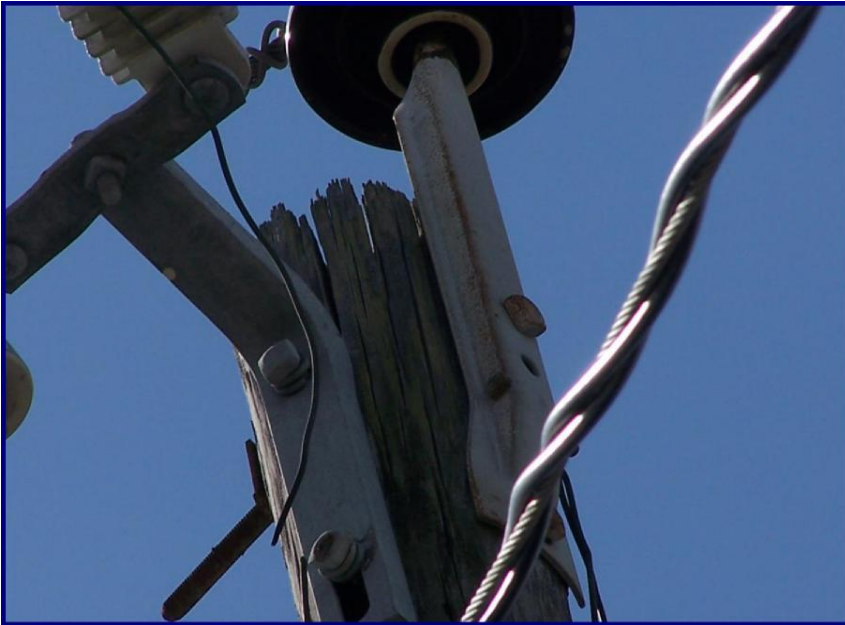

DECAYED TOPS:

Poles with decayed tops where there is evidence of crowning and/or decay that is not in close proximity of through bolts or hardware should not be considered for replacement based on the pole top condition.



Poles with split tops that affect the integrity of through bolts or hardware and that do not have additional through bolts running perpendicular to the split (holding the split together) is recommended for replacement, regardless of ground line conditions.



SPLIT TOPS:

Poles with split tops that have through bolts running perpendicular to the split should **not** be considered for replacement based solely on the pole top condition. The through bolt perpendicular to the split holds the pole together. The DTE spec requires split bolt for ridge pin installation.

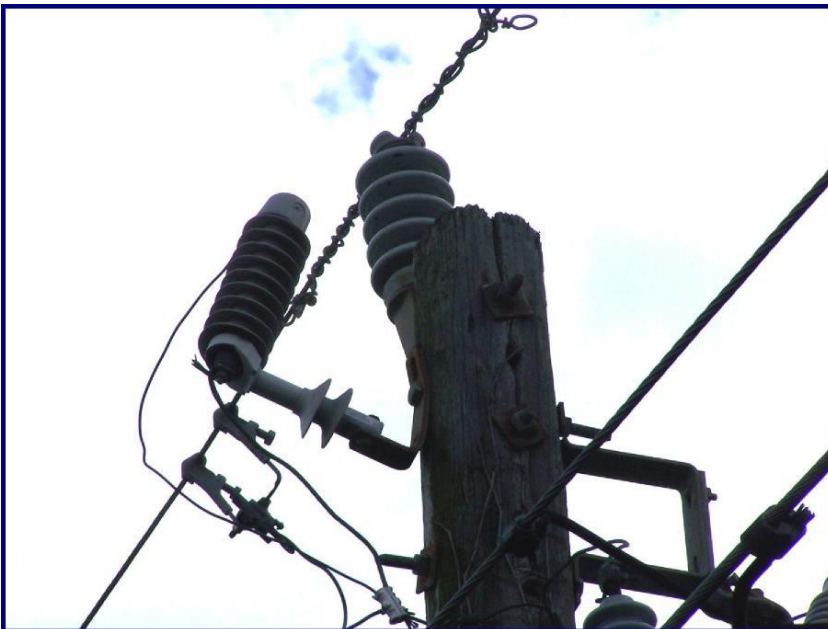

SPLIT TOPS:

Poles with split tops that do not affect through bolts or hardware integrity should be reported but should **not** be considered for replacement.



SPLIT TOPS:

Poles with split top with no through bolt running perpendicular to the split is recommended for replacement based on the pole top condition.



SPLIT TOPS:

Poles with top of the pole breaking off as the result of a split top and negatively impacting the hardware, failed pole visual inspection is recommended for replacement.



SPLIT POLE

Poles with deep and large cracks going from top to bottom of the pole, fails visual inspection and it is recommended for replacement



WOODPECKER HOLES:

Poles with woodpecker holes around bolt holes (peck out) and that do not affect the integrity of the hardware should not be considered for replacement based on the pole top condition.



WOODPECKER HOLES:

Poles with woodpecker holes around or below the hardware that appear to be hollow or the back of the hole can not be determined are recommended for replacement.



WOODPECKER HOLES:

Poles with woodpecker holes that are going through the pole are recommended for replacement.



COMPRESSION WOOD:

Poles with severe compression wood damage which result in horizontal cracking that penetrates one inch deep into the poles shell or covers a large portion of the poles surface should be are recommended for replacement.

Compression wood damage that is moderate should be noted under other pole conditions.

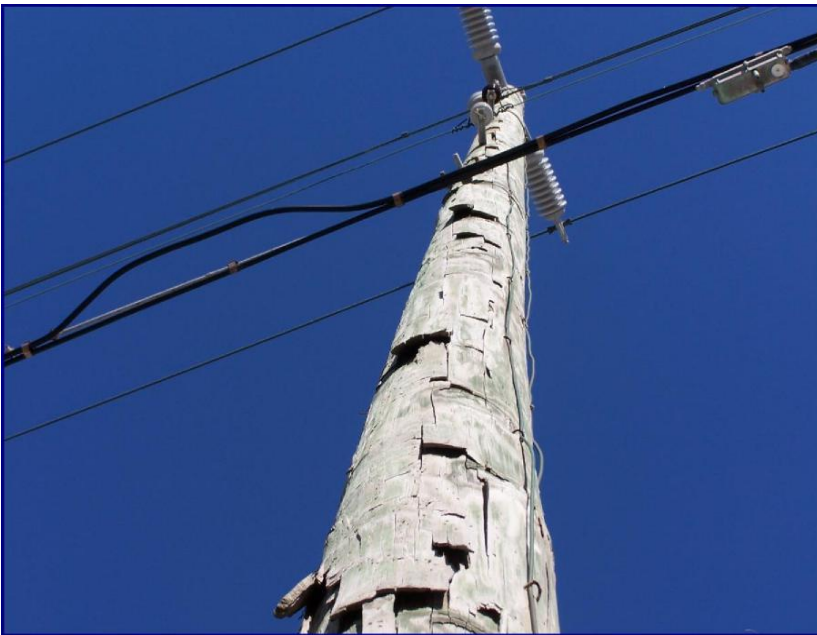

SPUR CUTS:

Pole with moderate damage as a result of spur cuts from excessive climbing should **not** be considered for replacement based solely on this condition. Spur cuts that are moderate should be noted under other pole conditions.



SPUR CUTS:

Pole with severe spur cut damage as a result of excessive climbing, are recommended for replacement based on this condition. Damage that results in a minimum of 1 inch of the poles outer shell being removed should be considered for replacement.

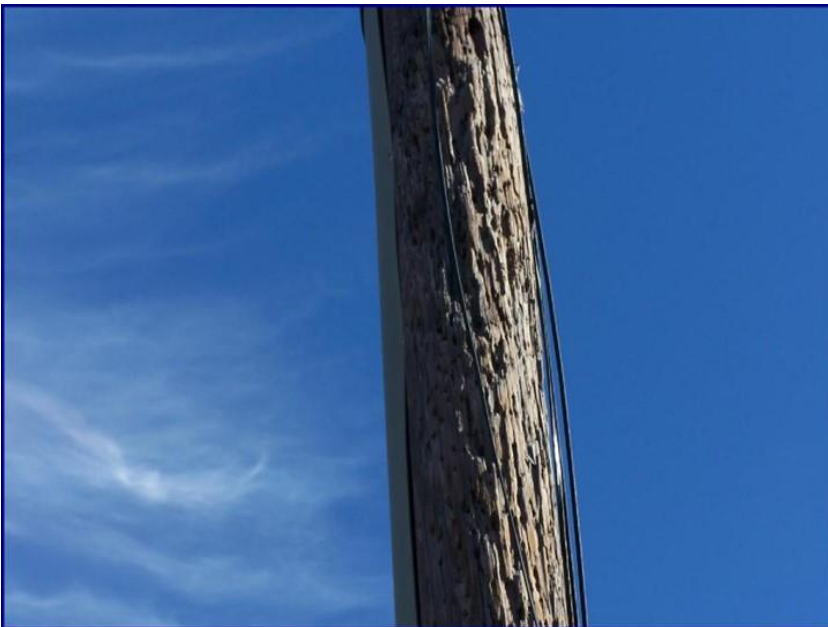

MECHANICAL DAMAGE:

Pole with moderate damage as a result of vehicles, non-environmental factors, or vandalism that are from the result of man-made forces from accidental or purposeful actions. Moderate mechanical damages can be defined as damages that will cause question of the structural integrity of the structure such as structure shell loss or large cracks. Damage that results in a minimum of 1 inch of the poles outer shell being removed should be considered for replacement.



FIRE DAMAGE:

Pole with moderate damage as a result of equipment failures, environmental factors, or vandalism that are from the result of fire, lightning strikes, or set fires. Damage that results in a minimum of 1 inch of the poles outer shell being compromised should be considered for replacement.



Objective

The objective of the Pole Top Maintenance Specification is to maintain the system's mechanical and electrical integrity, for the safety of DTE employees, contractors, and the public under the conditions specified by IEEE, vendor recommendations and DTE approved standards. This objective is accomplished by inspecting and testing pole top distribution equipment to identify any equipment that do not meet conditional requirements. The pole top equipment mentioned in this document will be reported or replaced, based on the criteria specific in this document. The inspection criteria apply to all DTE pole top equipment.

Scope

This specification is intended as a basis for the inspection and replacement of pole top equipment. As a result of the pole top inspection program, all pole top equipment that meet the in-service criteria will be inspected on a 5-year cycle. Pole top equipment inspected within the last 5 years shall not be re-inspected.

Urgent Repairs

Following scenarios need to be reported immediately if there are found:

- **Contact** [REDACTED] **for the following:**
 - Downed Wire
 - Floating Neutral
 - Wrapped Primary or Secondary
 - Broken Pole
 - Large limbs on conductor
 - Exposed Cables
 - Wires touching buildings
 - Problems that need immediate attention
- **Contact** [REDACTED] **for any transformers leaking oil** (Ground level or Over-head look thesame.)

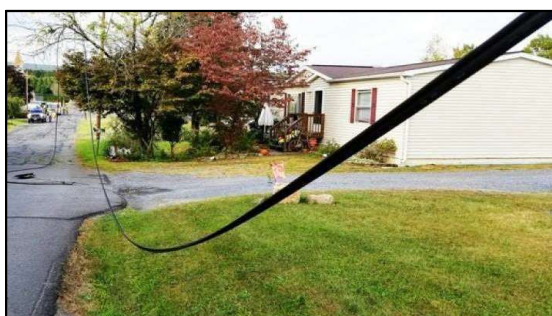

Downed Wires to be reported immediately



Transformers with Oil Leakage to be reported immediately.

The equipment listed below is to be reported if PCB contamination is found.

Transformers – PCB Contamination:

Defects:

Transformers contaminated with PCB need to be reported and replaced.

Dark shaded transformers and porcelain/glass insulators are the main visual cues for PCB contamination. Other methods of finding contamination goes as follows (see photos below).

- o Dark grey and black shade on the body of the transformer
- o Brown, white, and glass- porcelain type of insulators on the transformers for the primary and secondary bushing
- o Pole construction may also have porcelain insulators, arresters, and or vintage fuse holders
- o It should be assumed that units manufactured prior to July 1979 contain PCB
- o Check for nameplates for manufactured dates. Plates might be faded in many cases

Older units may not have any indication of date of manufacture which is an indicator of possible contamination

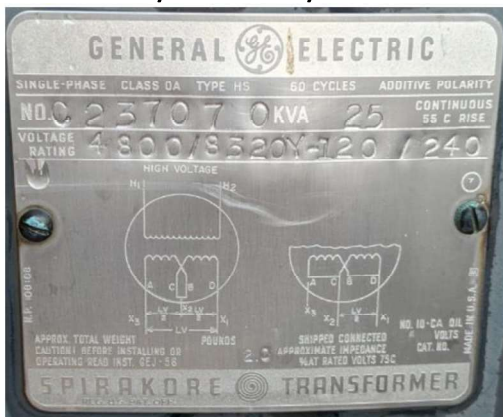

- No PCB-related verbiage ✗
- No visible date of manufacture ✗

Newer units will indicate non-PCB verbiage and key manufacture moth/year



- Non-PCB verbiage ✓
- Manufacture date is 05/09, if it indicates beyond 01/80 it is PCB free ✓

POLE TOP MAINTENANCE SPECIFICATION

PCB Contamination (CONT):



An example of a dark shaded transformer with porcelain insulators that have a shine during daylight.

POLE TOP MAINTENANCE SPECIFICATION

CUTOUTS:

Defects:

Porcelain cutout: To be replaced

Polymer cutout: Burnt, Melted, Arching.

Engineering Standards / Bulleting reference:

Verify with DTE if any document has been updated

EB-2005-OH-05 (See appendix)

All porcelain cutouts must be replaced; only polymer cutouts are the current standard. Polymer cutout should be replaced if the cutout is burnt, melted, and arcing. More reference on EB-2005-OH-05 / EB-2005-OH-05



Porcelain Cutouts: S&C R9, R10, AB Chance Cutouts

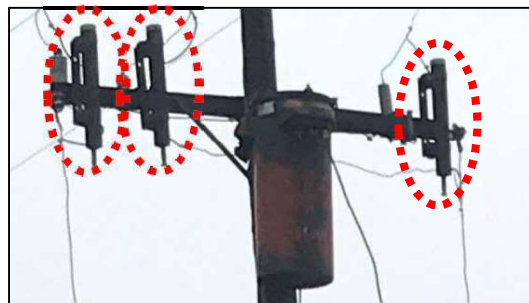
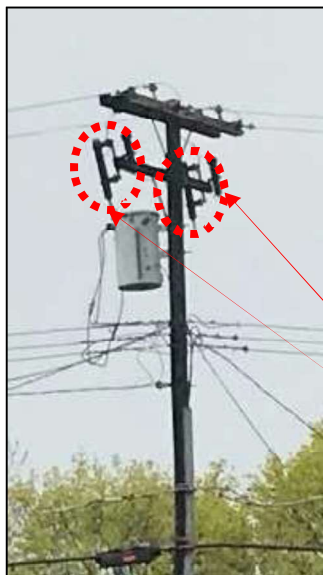

Cato Fuse Porcelain Cutouts

Locations of cutouts

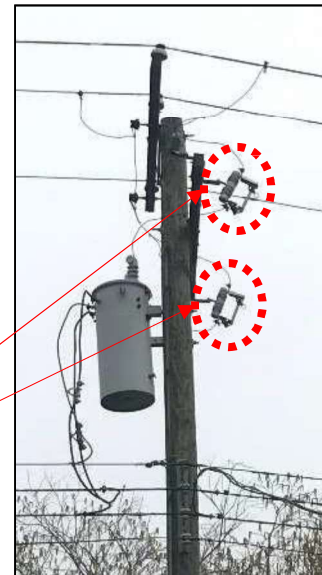

CUTOUT (Cont.):

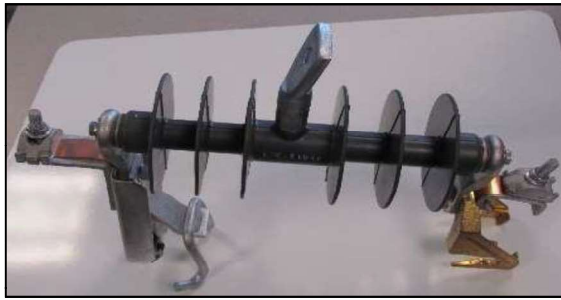

Acceptable Hubbell Power Systems Polymer Cutout



Acceptable S&C Electric Polymer Cutout

Also look for broken cutouts as shown below:

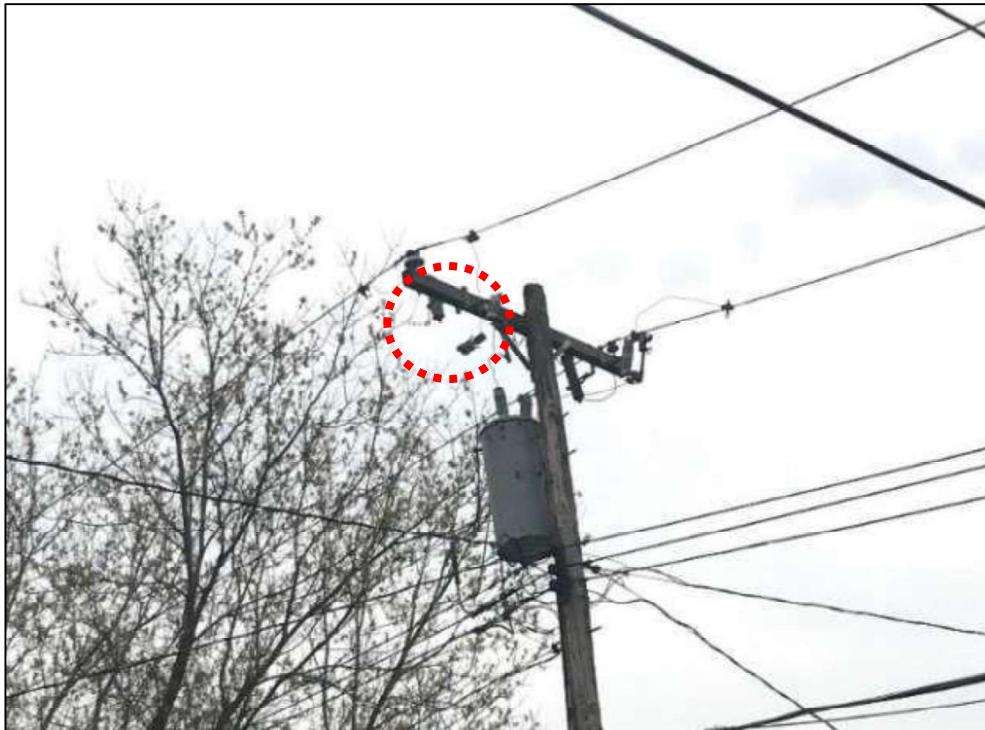

Broken S&C Porcelain cutout just above the transformer

The equipment listed below is to be *reported* if the items are **defective**.

CABLE POLE DISCONNECTS:

Defects:

Cable Pole Porcelain Disconnect Switch: To be reported if is cracked.

Cable Pole Polymer Disconnect Switch: To be reported if is burnt, melted, arching.

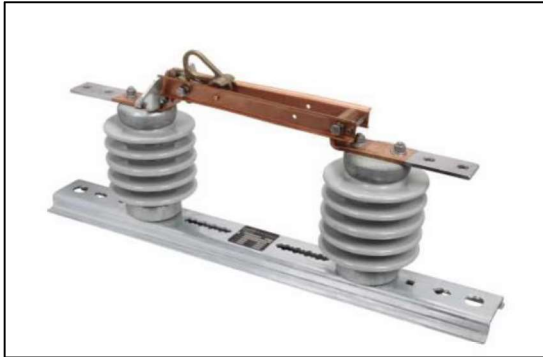

Acceptable Porcelain Disconnect Switch

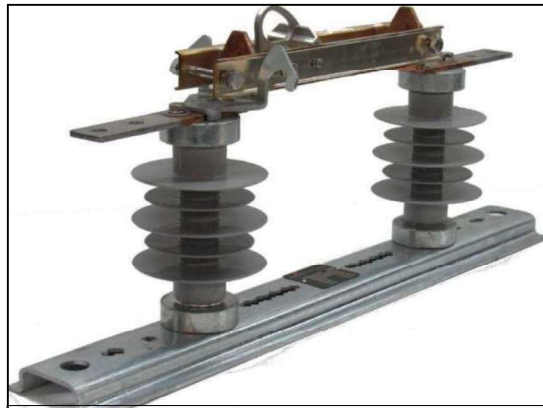

Acceptable Polymer Disconnect Switch

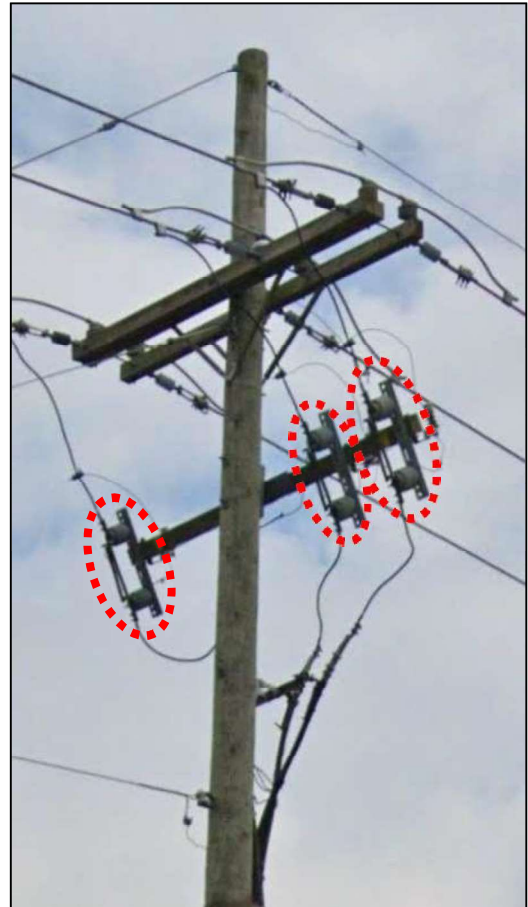

Location of Disconnect Switch

AUTOMATIC SLEEVES:

Defects:

Automatic Sleeves: To be replaced

Compression Sleeves: Broken Wires.

Engineering Standard / Bulleting reference:

Verify with DTE if any document has been updated

EB-2014-OH-10 (See appendix)

Any automatic sleeves must be replaced; the current standard is the compression sleeve. Compressionsleeves must be replaced if the conductor, on either side, has a broken wire. Reference EB-2014-OH-10

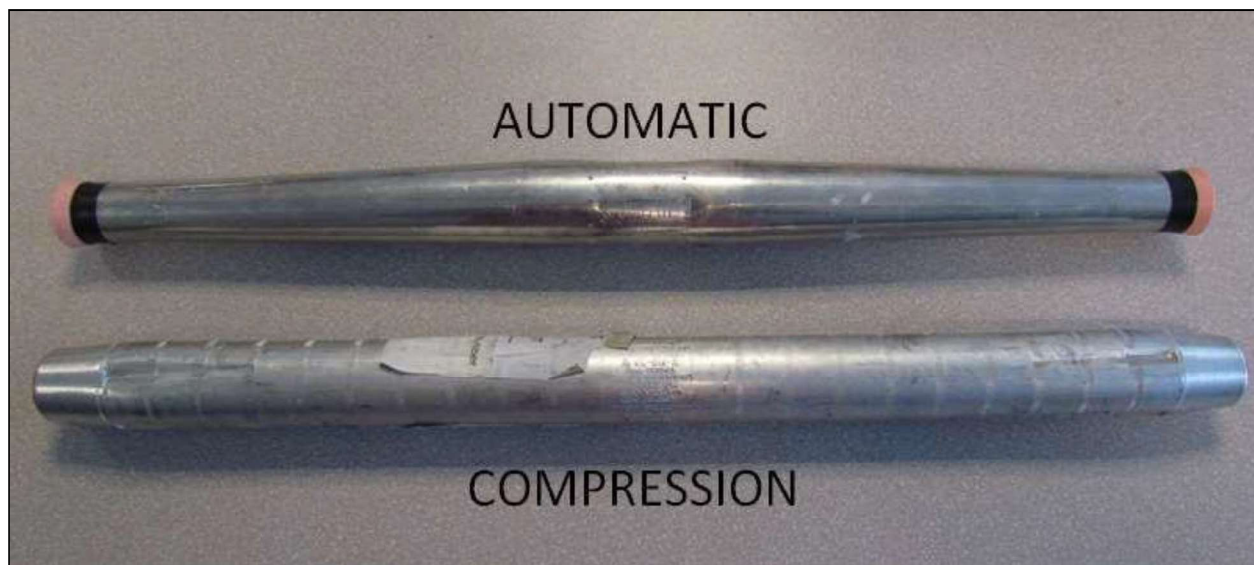

Automatic Sleeve to be reported.

POLE TOP MAINTENANCE SPECIFICATION

BLACKBURN HOT TAPS:

Defects:

Blackburn: To be replaced

Engineering Standards / Bulleting reference:

Verify with DTE if any document has been updated

EB-95-OH-34 (See appendix)

According to EB-95-OH-34 the Blackburn taps should be removed and replaced with an approved tap.



Blackburn Hot taps shall be reported and replaced

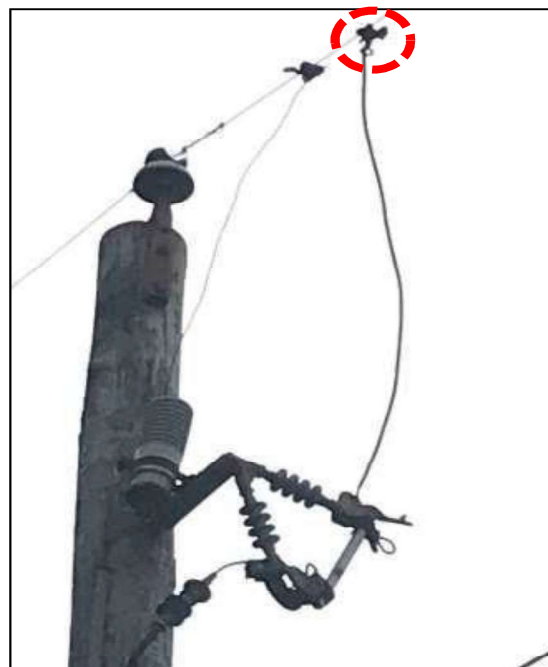

Location of Blackburn Hot Tap

The equipment listed below is to be *reported* if the items are **defective**.

GROUND WIRE:

Defects:

Ground Wire: To be reported if is broken, missing or detached from pole.

Any missing ground wire, must be replaced. The ground wire goes inside the plastic molding and must be continuous from the top of the pole to the ground. In the case described below wire and molding should be replaced.

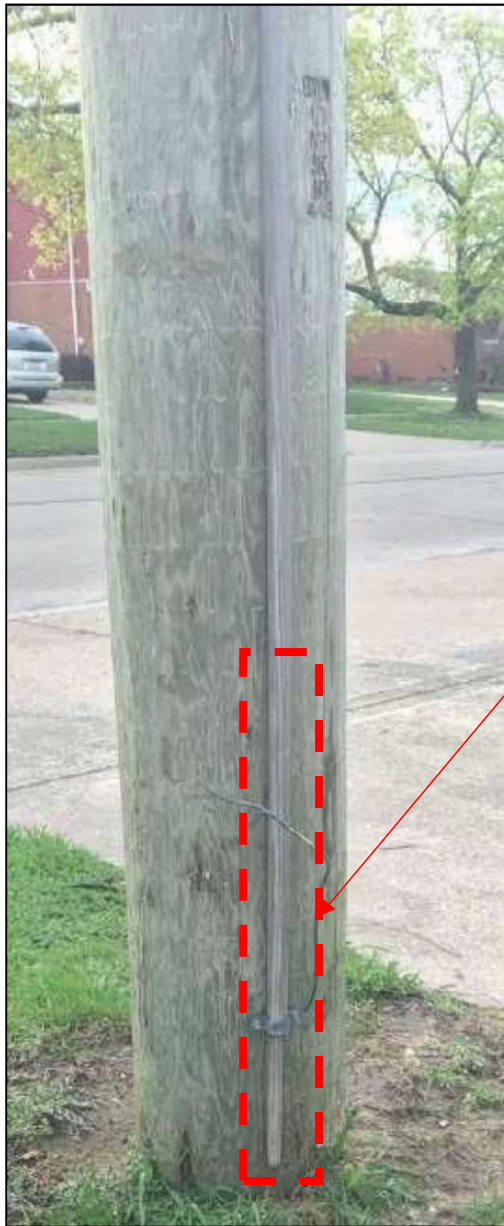

Acceptable Ground Wire. Continuous from top of the pole all the way until the floor



Defective Ground Wire (non-continuous)

Difference

POLE MAINTENANCE SPECIFICATION

The equipment listed below is to be *reported* if the items are **defective**.

Defects:

Burn Conductor/Sensor: To be reported if the conductor/sensor show signs of burning.

All smart fault Indicators that show signs of burning on either the conductor wire or sensor needs to be reported and replaced. Sensor will typically show signs of damage on the duckbill and eyebolt. Attached are photos of the burned conductors and sensors.



Burned Conductor

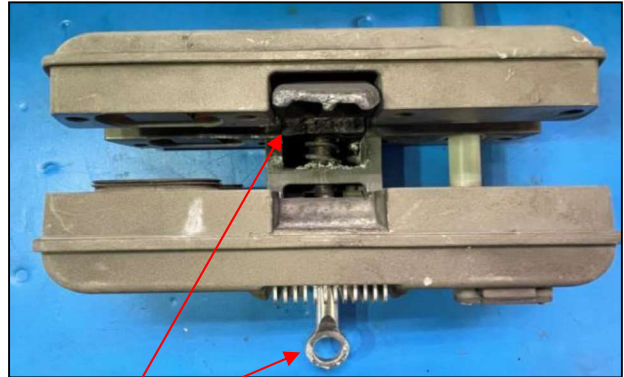

Burned Smart Fault Indicator



Location of the Smart Fault Indicators

The equipment listed below is to be *reported* if the items are **defective**.

ARRESTERS:

Defects:

Arresters: To be reported if blown Isolator, melted, burnt or arching.

Arresters that have a blown isolator must be replaced. The arrester should be replaced if melted, and burnt, arcing. All Vari-Gap designed arresters must be replaced broken or unbroken. The Vari-Gap arresters stopped being installed in 2002.

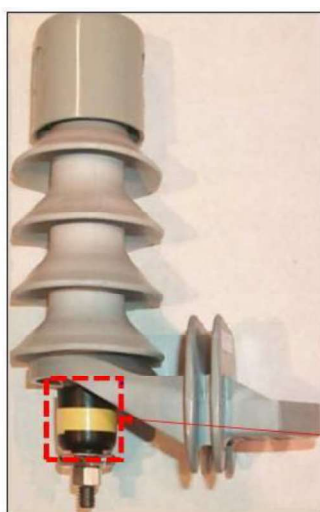

Acceptable 13.2kV Arrester

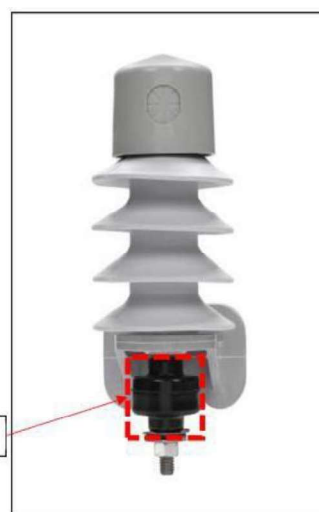

Acceptable 4.8kV Arrester

Intact Isolator

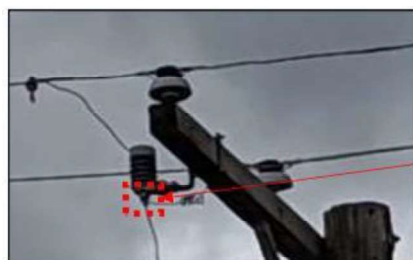

Acceptable Arrester

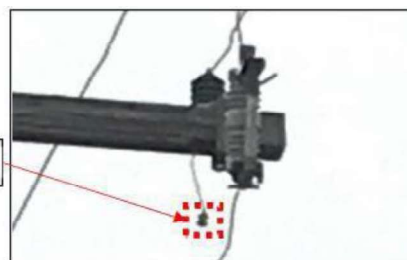

Defective Arrester, is not connected

Difference



Side View of Arrester



Top View of Arrester

Vari-Gap Arrester

POLE MAINTENANCE SPECIFICATION

The equipment listed below is to be *reported* if the items are **defective**.

CROSS-ARM PARTS:

Defects:

Cross-arms: To be reported if is broken, cracked/decayed and affecting hardware.

Cross-arm Brace: To be reported if is broken, cracked/decayed and affecting hardware.

Cross-arm Brace Nut-Bolt: To be reported if is missing.

Cross-arm Nut-Bolt: To be reported if is missing.

Cross-arm Pin Insulator: To be reported if defective and affecting hardware.

Cross-arms or braces that are cracked, warped, or broken, must be replaced. If a fiberglass cross-arm is missing any end caps, the cross-arm must be replaced

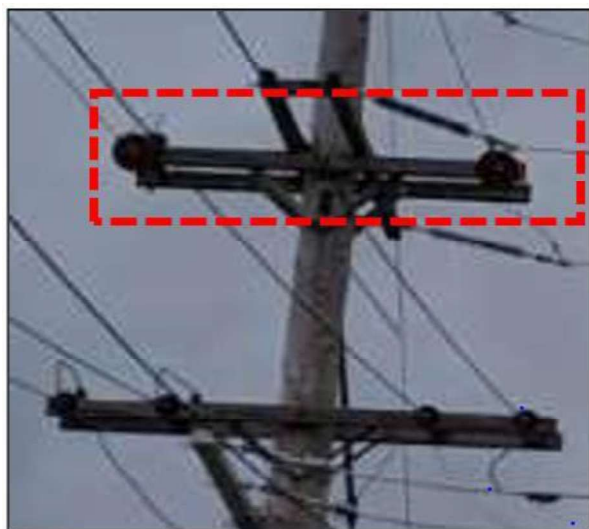

48" Acceptable cross-arm

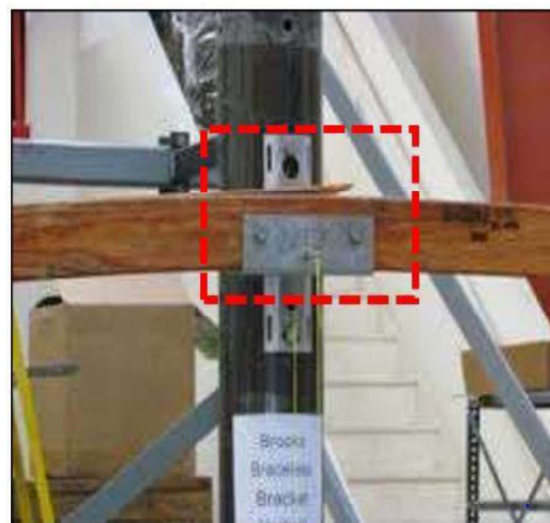

Cracked 48" cross-arm that needs to be replaced.

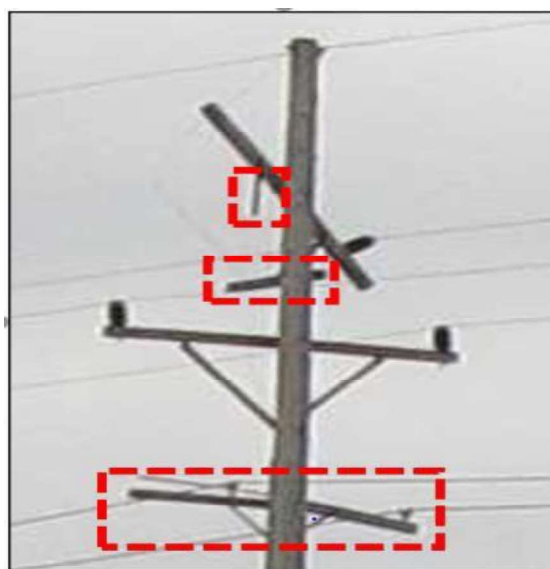

Defective 120" Cross-arms

POLE TOP MAINTENANCE SPECIFICATION

CROSS-ARM PARTS (Cont.):



Acceptable Fiberglass Cross-arm

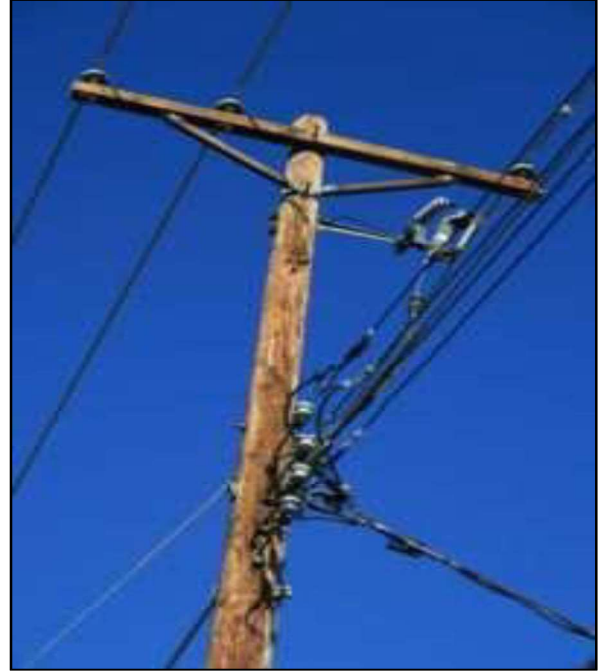

Acceptable 96" Cross-arm

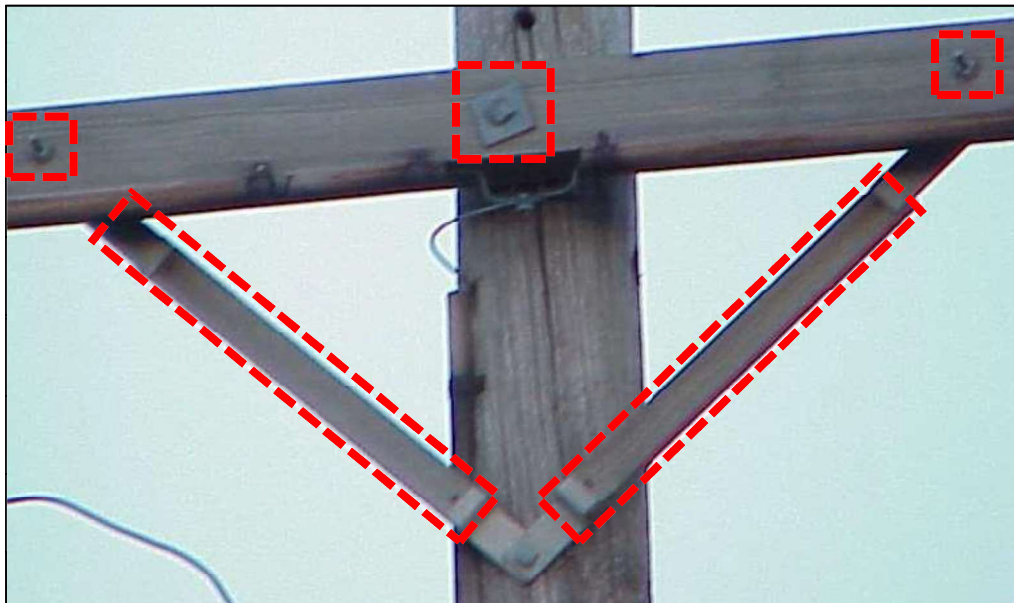

Acceptable Cross-arm Braces, Brace Components, and Cross-arm Components

The equipment listed below is to be *reported* if the items are **defective**.

TRANSFORMER PARTS:

Defects:

Transformer Nut-Bolt: To be reported if missing

Check bolts and nuts.

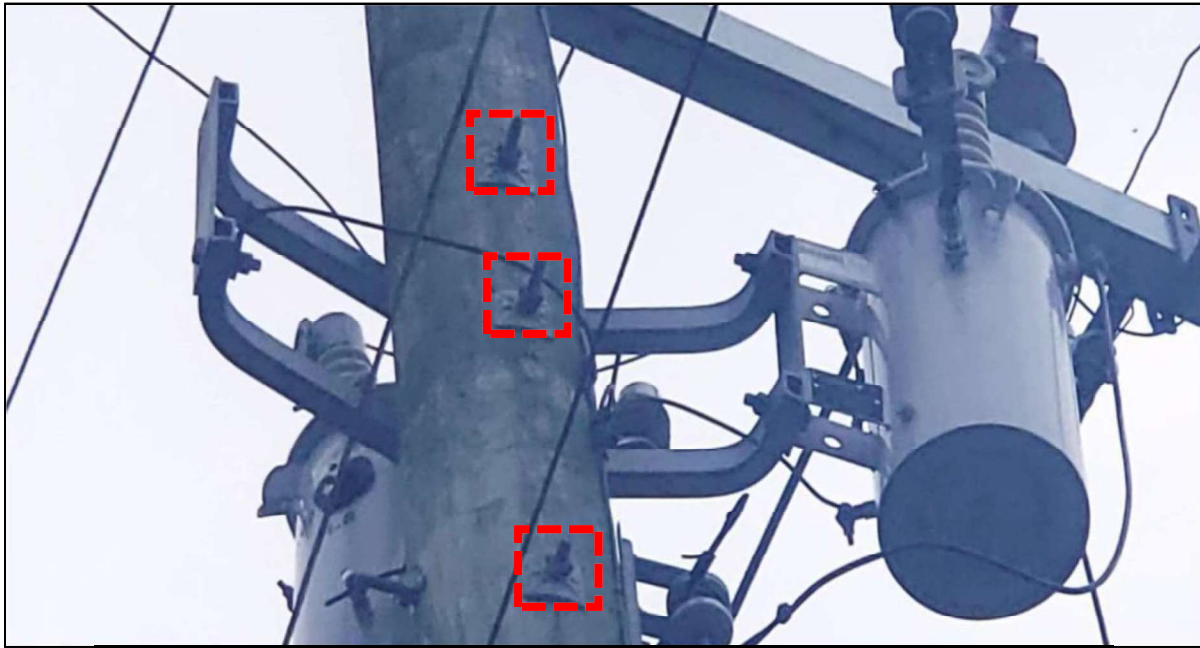

Acceptable Transformer Nuts and Bolts. Report it if some of them is missing.

POLE TOP MAINTENANCE SPECIFICATION

The equipment listed below is to be *reported* if the items are **defective**.

DISC AND PIN INSULATORS:

Defects:

Disc Insulator: To be reported if is cracked

F-neck Insulator: To be reported if is cracked Porcelain Post

Insulator: To be replaced

Polymer Post Insulator: To be reported if is burnt, melted, arching, cracked Insulator Nut-

Bolt: To be reported if is missing

Engineering Standards / Bulleting reference:

Verify with DTE if any document has been updated

EB-99-OH-2 SB-2005-OH-02 (See appendix)



Acceptable F-neck, Disc, and Line-Post



Defective Line-Post Insulator



Defective Disc

The equipment listed below is to be *reported* if the items are **defective**.

DISC AND PIN INSULATORS (Cont.):



Insulator locations



Damaged insulator

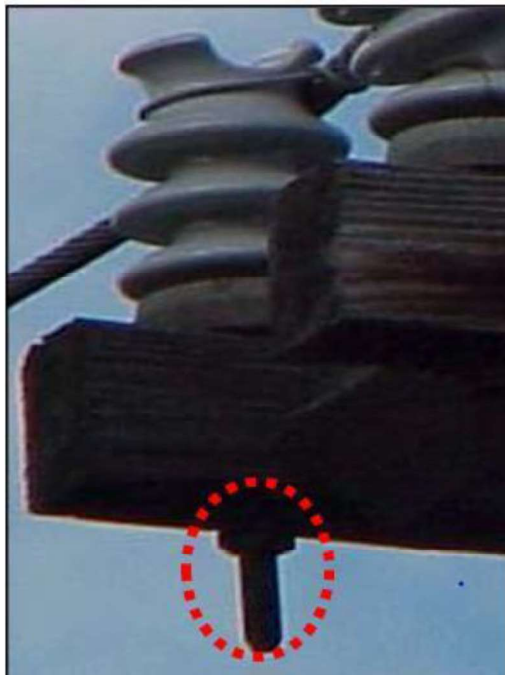

Acceptable Nut and Bolt, report if missing

POLE TOP:

Defects:

Pole Top: To be reported if decay affects hardware

Pole tops that impact the integrity of any hardware and do not have a through bolt, must be replaced.



Defective Pole Top



Acceptable Pole Top

PRIMARY LINE SAG:

Defects:

Primary lines: To be reported if is over sagged

If a line is too loose then it shall be re-tensioned or replaced.

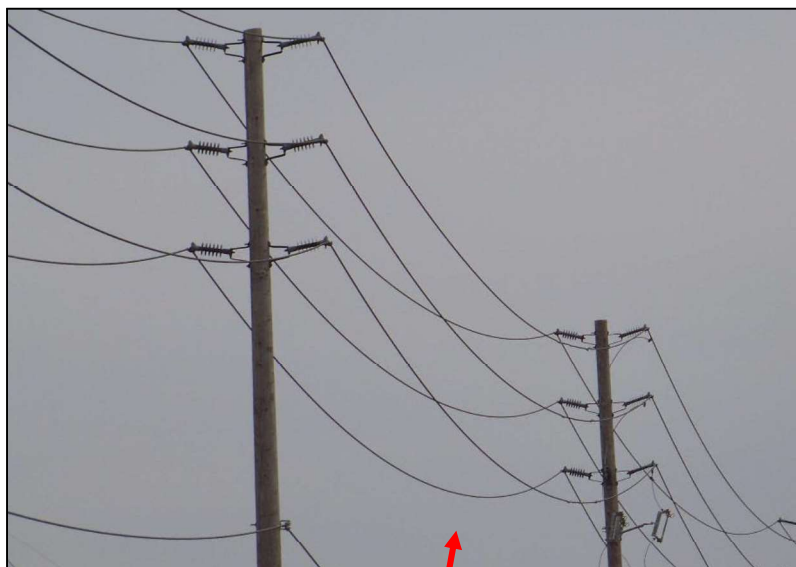

Acceptable Line Sag

The equipment listed below is to be *reported* if the items are **defective**.

ALL RELATED GUY WIRE COMPONENTS:

Defects:

Guy wires: To be reported if broken strands are observed or it is loose. **Johnny Ball:** To be reported if it's broken or disconnected.

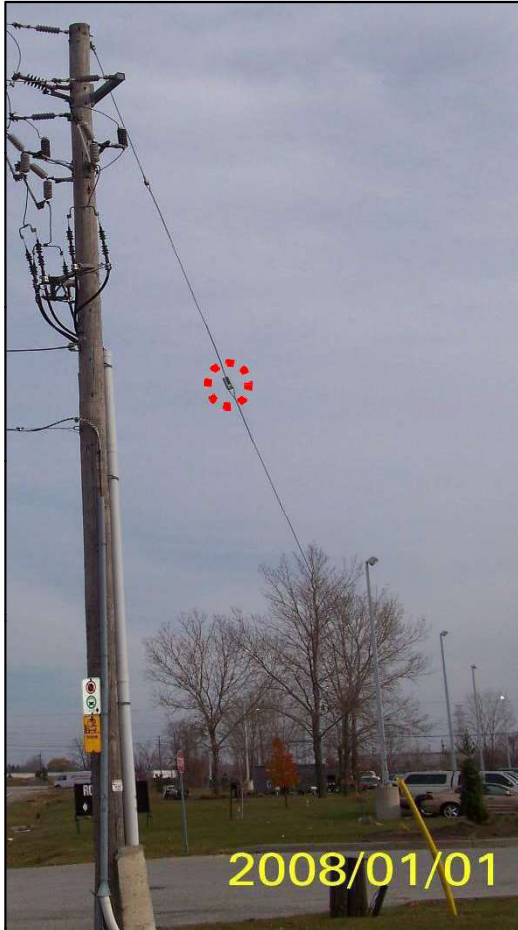

Acceptable Guy Wire and Johnny Ball



Defective Guy Wire



Defective Johnny Ball

The equipment listed below is to be *reported*, only if there is an item that is **defective** from the above/previous listings on the same pole.

SPACER BLOCK:

Defects:

Spacer block: To be reported if it's broken and affecting hardware.

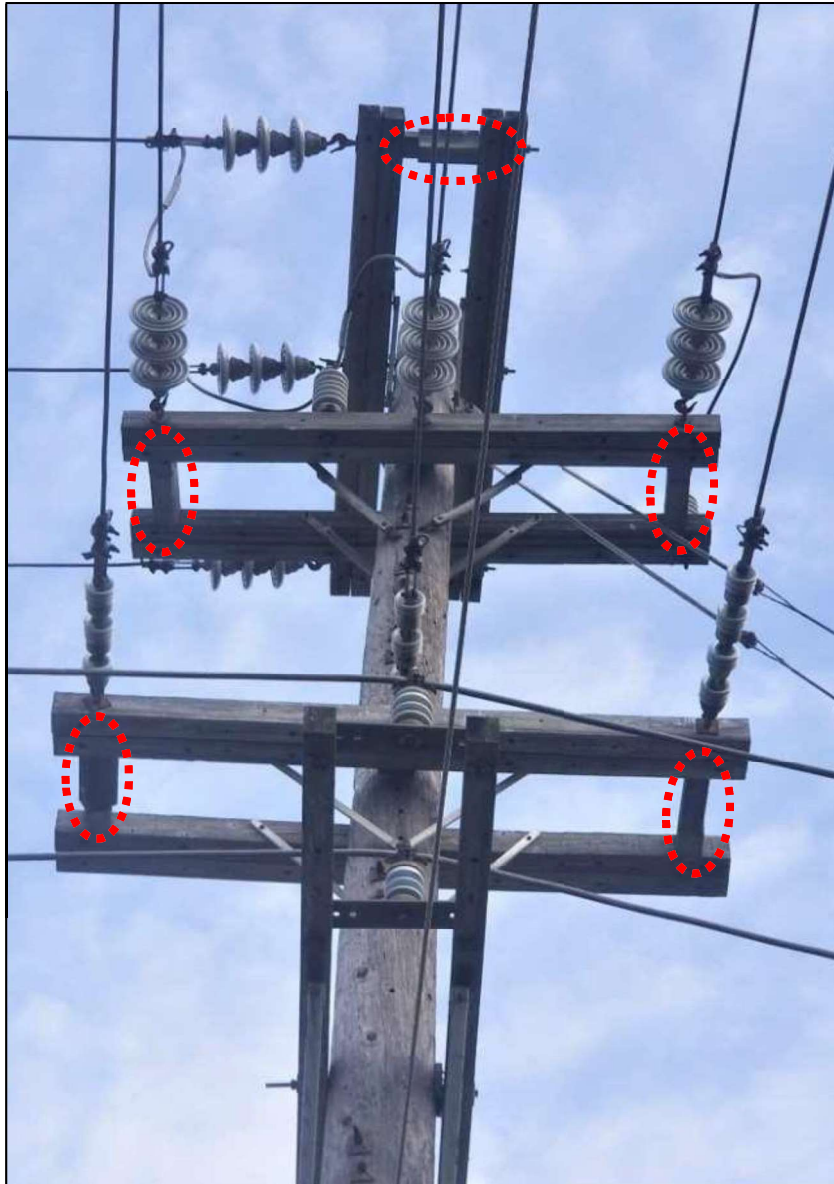

Acceptable Spacers Blocks. If some of the spacer block is broken, it should be reported.

The equipment listed below is to be *reported*, only if there is an item that is **defective** from the above/previous listings on the same pole.

NEUTRALS ON SECONDARY TAP:

Defects:

Neutrals on secondary taps: To be reported if it's disconnected

Neutral should be reported if it's disconnected. For more details see the diagram below.



Acceptable Neutral Tap on Secondary

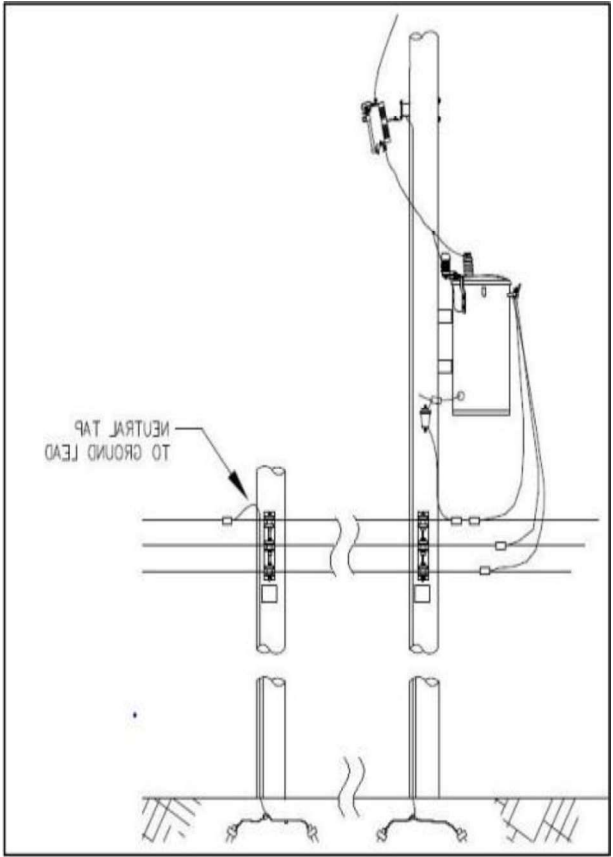

Diagram of good connections on the neutral

The equipment listed below is to be *reported*, only if there is an item that is **defective** from the above/previous listings on the same pole.

SECONDARY EQUIPMENT:

Defects:

Secondary Spool: To be reported if it's broken

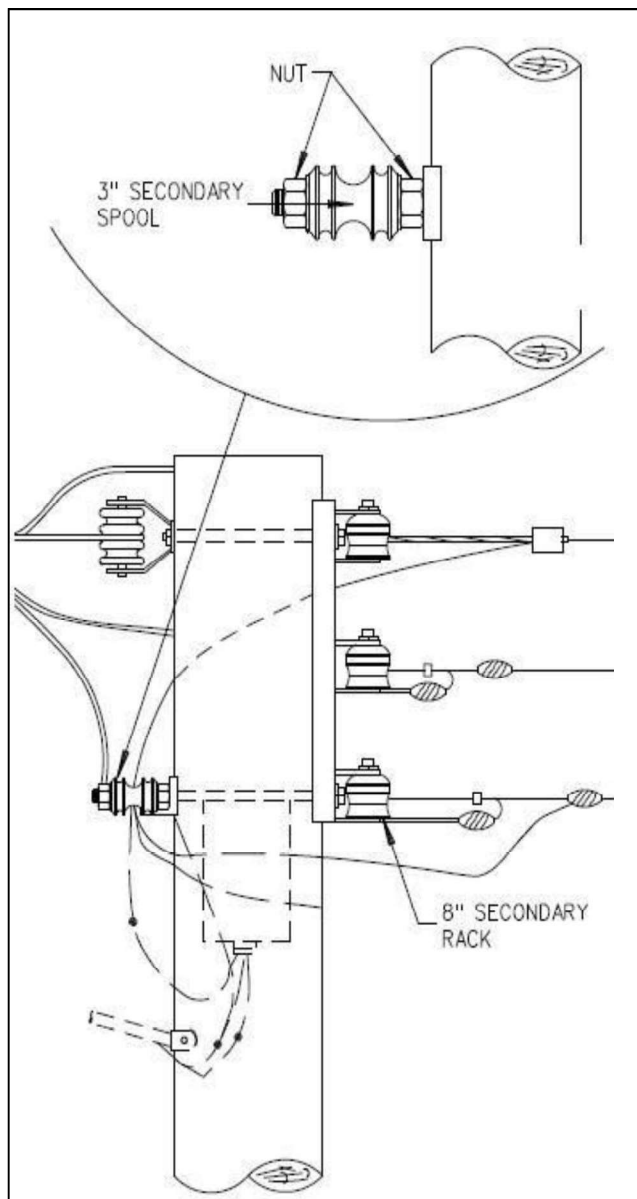

Acceptable Secondary Spools and Rack



Acceptable Neutral Spool Assembly



Acceptable Spool Rack

If any of the elements contained in the picture is broken including porcelain insulators, rack, or bolts should be reported

The equipment listed below is to be *reported* if the items are **defective**.

ALL RELATED Fiberglass Brackets:

Defects:

Fiberglass Brackets: To be reported if bracket shows signs of damage.

Fiberglass brackets may experience discoloration, warping, delamination, blistering, and cracking. Attached below are photos of the different fiberglass brackets that out in the field.



Single Phase Fiberglass Bracket with Insulator



Single Phase Fiberglass Bracket



Three Phase Equipment Fiberglass Bracket



Single Phase Fiberglass Bracket

Appoline Strategic Undergrounding Pilot Project

February 28, 2024 Update

Contents

Appoline Background 3
Appoline Costs 4
Appoline Status 4
 Summary of Lessons Learned 6
 Conclusions 7
Appendix – Images for the Appoline Pilot 8

Appoline Background

In late 2018, DTE Electric initiated a pilot project on Appoline DC 1346 in Detroit to move rear-lot overhead assets to rear-lot underground infrastructure. Appoline DC 1346 had poor reliability and wire down performance. Converting Appoline from overhead to underground infrastructure would reduce outages, improve reliability, and reduce O&M costs. The goals of the Appoline pilot project were to determine actual installation costs, understand customer acceptance, and determine opportunities to improve cost and construction efficiency. The pilot project was focused on 61 customers in two blocks in the City of Detroit. The scope of the pilot project includes the installation of a looped Underground Residential Distribution (URD) system with approximately 1,300 feet of primary, six transformers, and underground services to residences. It also includes removing the overhead infrastructure when the underground scope is complete.

Figure 1: Two City Blocks for Rear-Lot Overhead to Rear-Lot URD Conversion
Yellow Lines – URD cable loop / Dashed Red Lines – Secondary / Square – Pad-mount Transformers / Circles – Pedestals



*Two Block Scope of the Appoline Pilot
Yellow Lines Indicate where the URD is installed (rear-lot)*



*A More Focused View of the North Block in the Two Block
Appoline Pilot Area Shown to the Left*

Figure 1 illustrates the scope of the pilot project. Appoline is a 4.8kV circuit that will be converted to 13.2kV at some point in the future, therefore the pilot project is being constructed to the higher

voltage standard, in a way that will allow for cost-efficient future conversion. A cable pole is installed on each end of the area with an “open” point near the center. This provides the redundancy that is typical for URD loops.

Appoline Costs

The original budget established for Appoline in 2019 was \$395,731. The total cost to complete the pilot project was \$895,000.

Appoline Status

As described in the Company’s 2021 Distribution Grid Plan, the goals of the Appoline pilot project were to determine actual installation costs, understand customer acceptance, and determine opportunities to improve cost and construction efficiency. The Appoline pilot project has accomplished those goals by installing a looped URD system in an established urban neighborhood. The work completed includes the installation of the URD system, which required 1,265 feet of primary and 740 feet of secondary to the pedestals to feed services. The Company also installed 2,775 feet of underground cable for the services going to each home, which were bored and installed in conduit. Six pad-mount transformers and twelve pedestals were installed in the rear-lot, which required extensive alleyway clearing and two rounds of tree trimming. As of mid-November 2023, 100% of the 61 customers in the two block Appoline pilot project area has been converted to the URD loop, and the remaining poles have been top cut. This completes all the planned construction for the Appoline pilot project.

The engineering and design phase of the work presented a rich area for learning. After the initial design, issues were identified in the field which prompted further examination into the plan. One of the primary concerns impacting the design was existing customer fencing and structures in the rear-lot alleyway. These impediments impacted where the pad-mount transformers could be located and required several design iterations. The Company had to work closely with the customers affected on identifying which fences could be removed and reinstalled for the new pad-mount transformers. For the transformer locations where the obstructions could not be removed or reinstalled, a new design was needed. This new design included switching from trenching to boring in some cases where the structures could not be relocated. Debris and overgrown trees and brush also presented design challenges. To perform the level of patrols needed to plan an executable design, debris and overgrown vegetation had to be removed. These design challenges caused increased costs and led to schedule delays. From the engineering and design work on Appoline, the Company captured several lessons learned to be implemented in future Strategic Undergrounding work. First, a thorough walkthrough is needed with all pertinent parties before design to capture all impediments for design and construction work. In addition, when planning future Strategic Undergrounding scope, additional cost should be allocated to potential debris clearing and tree trimming that may be needed. Finally, when considering installing URD in an

established neighborhood, the Company will plan for and include the increased cost of boring in the conduit.

Customer acceptance was another key aspect of the work. Signoffs from customers were needed to place equipment in their yards and to reroute their services on their homes from overhead to underground. The Company started by sending letters to customers, and then shifted to placing door hangers alone at customer locations. The next step was a door-to-door campaign to engage customers. Again, if the Company was unable to contact the customer in the door-to-door outreach, DTE Electric placed another door hanger, as shown in Figure 2, at the customer's home to provide that customer with an alternative way to contact the Company.

Figure 2: Door Hangers Left at Customer Homes

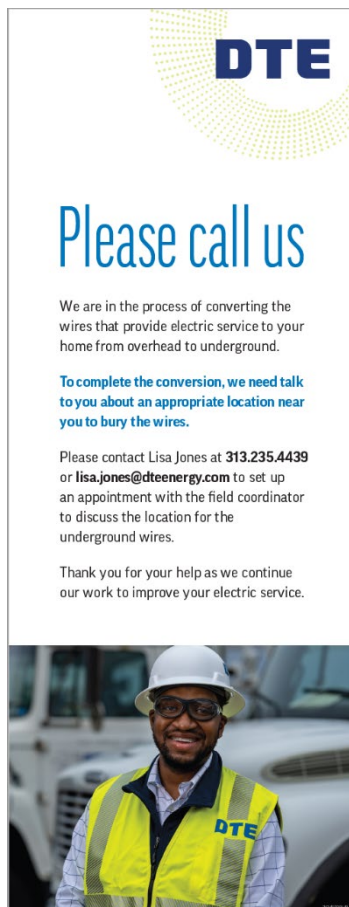

These methods proved to be successful in most cases, but reaching the owners of rental properties has been a major challenge. With this, the Company established partnerships with the local City

government and local community outreach partners. The Company kept the local government and community partners apprised of the status of the work and worked with them to help further engage the customers. The Company has also attended local town hall and community engagement meetings to further reach customers. Additionally, the Company engaged a communication company that partnered with a title agency. That partnership was able to identify the owners of the rental homes and provided the Company contact information for those owners. Finally, through a series of carefully crafted communications with property owners, the Company was able to complete the conversion of rental properties. Through these interactions, DTE Electric obtained a better understanding of what customer engagement strategies are vital for future Strategic Undergrounding work.

For the construction aspects of the work, additional vegetation trimming, debris removal, and obstacle mitigation was required to install the URD. Expanding these aspects during the design phase to avoid multiple rounds was another key learning. With the City giving the alleys back to the residents, many have extended their fence lines or added to their property (sheds, pools, landscaping, boats, vehicles, and one resident had an auto garage). With this, each location varied serving as its own project. This affected where pad-mounted transformers and pedestals were located. The field conditions also hampered the boring and trenching options. The waste that was removed from the alleyways included trash, roofing materials, yard waste, hazardous materials, rusted tools, hypodermic needles, tires, and propane tanks.

Summary of Lessons Learned

To install the pad-mounted transformers and prepare the site for the installation of the URD loop, the area first needed to be cleared of debris. During this process, the Company had to address a higher level of tree and brush removal than expected, several fences, a few garages in the previous alley right of way, and significant garbage removal. These cost and project schedule impacts would have to be remediated or considered in any future rear-lot undergrounding projects. Another significant challenge impacting the schedule of this pilot project was difficulty in contacting the customers to obtain approvals for modified attachments to their homes. After limited success using several mailings and door hangers only, the Company used door-to-door customer outreach, which allowed the Company to complete 25 services. The Company developed new methods of reaching customer agreements through the Appoline pilot project. Reaching 100% of property owners will be challenging and a mitigation strategy will be considered up front for future work.

In addition to what the Company learned from implementing the Appoline pilot, the Company also engaged in benchmarking efforts to identify best practices. Benchmarking has been done on Strategic Undergrounding among other infrastructure considerations with a dozen or so peer utilities. This work was to determine the optimum infrastructure configuration and construction methods that balance reliability, cost, constructability, and customer engagement when relocating infrastructure. The results overwhelmingly concluded that front-lot URD is the best option. Front-lot URD provides the best customer experience for both reliability and aesthetics. Key lessons learned from benchmarking efforts on how to improve efficiency of execution include the

importance of streamlined contracting for design, customer outreach, and construction and utilizing public right-of-way. The greatest challenge identified by other utilities for other configuration options was community acceptance.

Conclusions

The Company has documented the key learnings that the Appoline pilot project set out to capture, and they are being used to plan future Strategic Undergrounding work. First, the Appoline pilot project has led the Company to an understanding of the challenges with contacting customers, specifically for rental properties, to obtain their agreement. Including these methods in future projects will provide for quicker and more cost-effective implementation. DTE Electric has also developed baseline installation costs by implementing the Appoline pilot for rear-lot construction. That cost information and the lessons learned by the real-world implementation of the pilot project in the field have been used to develop new methods for the next stages of this important work. Furthermore, the Appoline pilot project is a small scale of work with only 61 homes in two blocks included in the scope. Performing undergrounding work on a larger scale will lead to efficiencies with underground resources, equipment, and material cost.

Appendix – Images for the Appoline Pilot

Appoline prior to tree trim removal (first round)



Appoline prior to tree trim removal (second round)



Appoline after tree trimming



Appoline customer connections – before and after

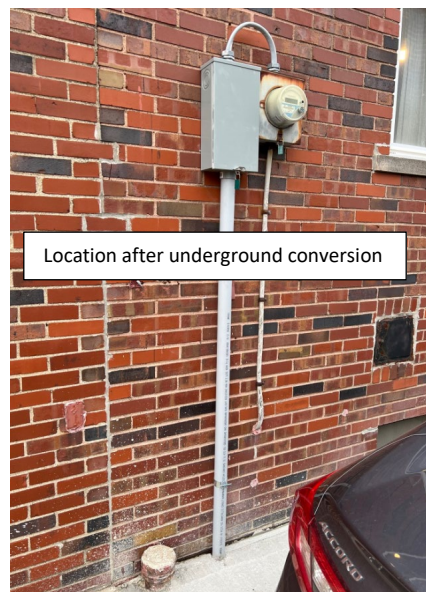
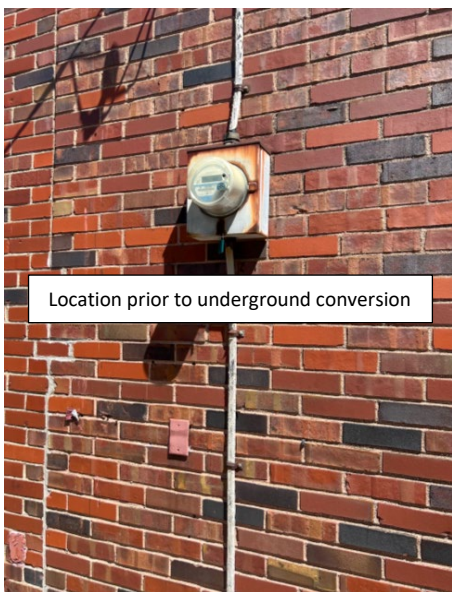
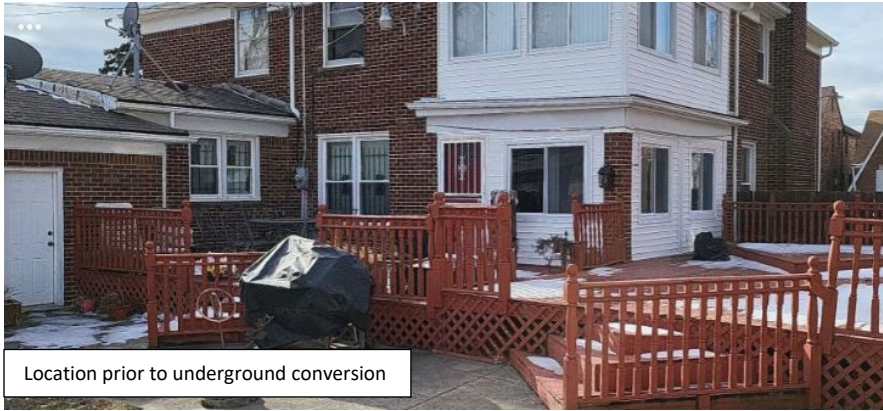

Appoline construction complete



Appoline installed underground pedestals and transformers





Technical Conference

March 22, 2023

Today's Agenda

- **Conference kickoff (15 min)**
- Context and background
 - Overview of DTE's 4.8kV distribution system (45 min)
 - 4.8/13.2kV distribution systems and the integration of EVs and DERs (15 min)
 - The Detroit 4.8kV System and PLD arc wire (15 min with Hardening)
- 4.8kV Hardening Program (45 min)
- 4.8kV Hardening program and alternative solutions (1 hr)
- Open table discussion/conference feedback (30 min)

Conference Kickoff

- DTE kickoff and welcome

Today's Agenda

- Conference kickoff (15 min)
- **Context and background**
 - **Overview of DTE's 4.8kV distribution system (45 min)**
 - 4.8/13.2kV distribution systems and the integration of EVs and DERs (15 min)
 - The Detroit 4.8kV System and PLD arc wire (15 min with Hardening)
- 4.8kV Hardening Program (45 min)
- 4.8kV Hardening program and alternative solutions (1 hr)
- Open table discussion/conference feedback (30 min)

DTE's distribution system consists primarily of two voltages – 13.2kV and 4.8kV

System Map (Circuit voltage)

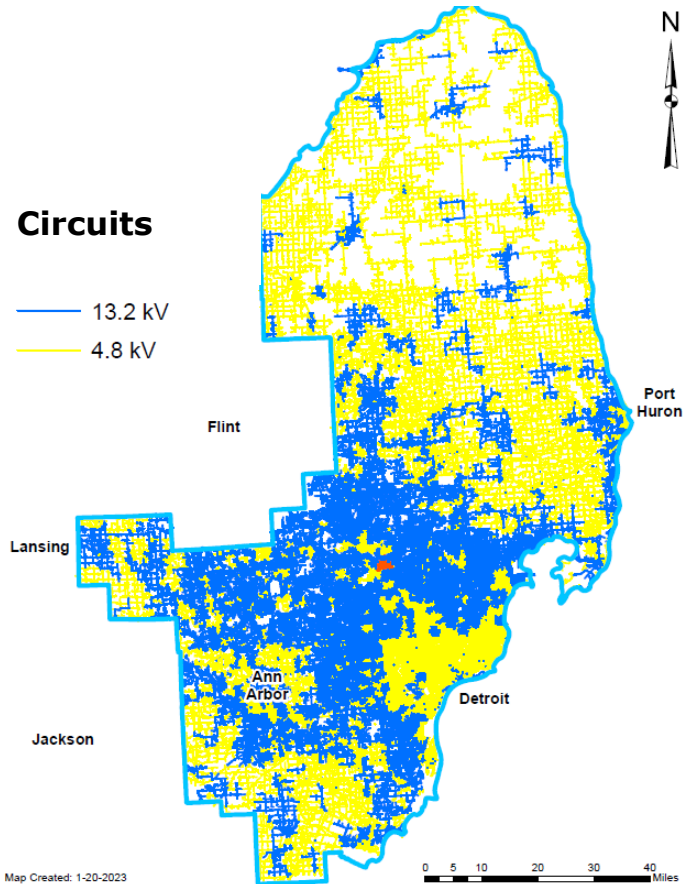

System Map (Substation Voltage)

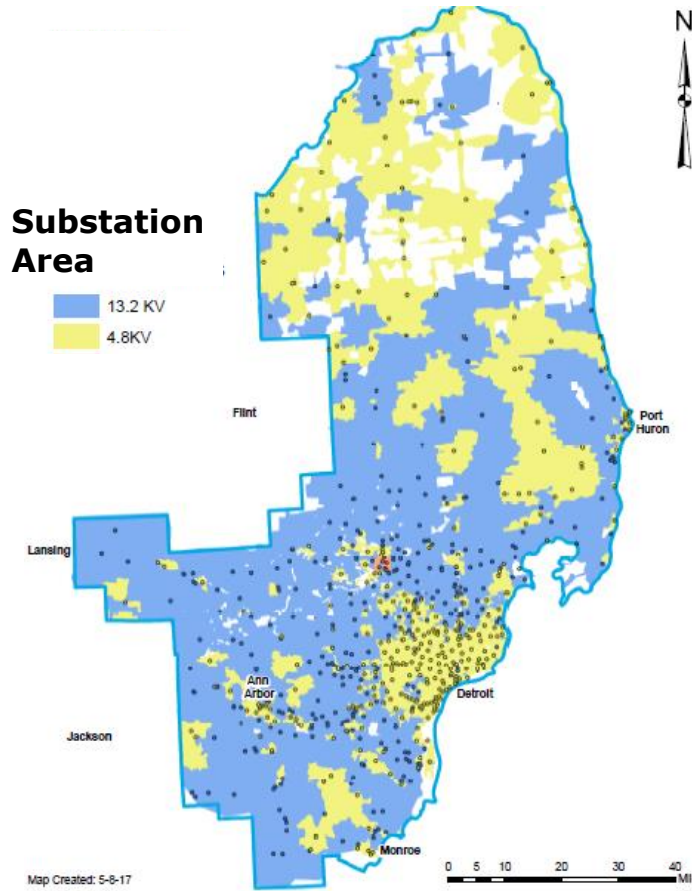

Customer Count (Circuit Voltage, 000's)

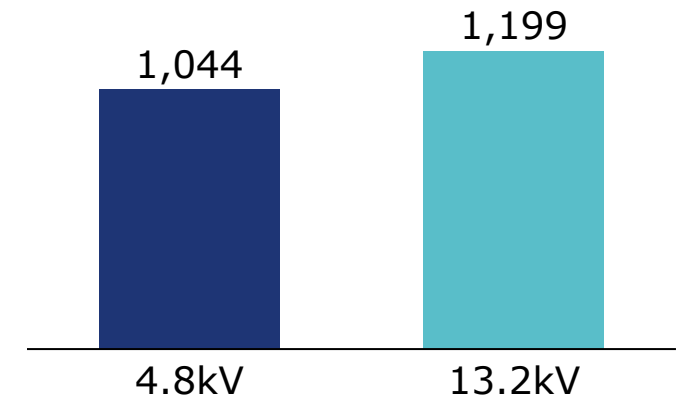

Customer Count (Substation Voltage, 000's)

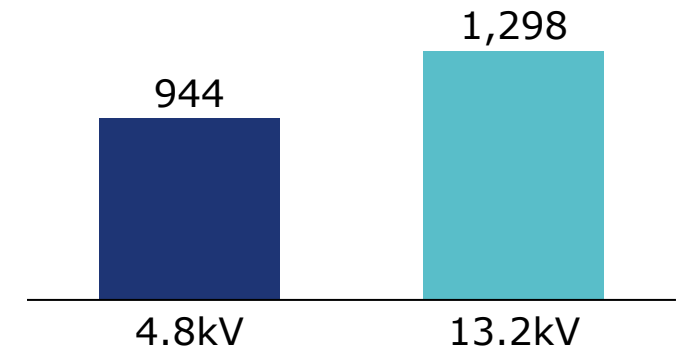

Some circuits on the system contain ISO down areas, which begin at a 13.2kV substation but voltage is stepped down to 4.8kV through isolation transformers serving ~100k customers across 5,500 line miles

Customers served by our 4.8kV systems, on average, experience fewer outages (SAIFI), but longer total duration (SAIDI)

All-weather SAIFI¹
by substation voltage

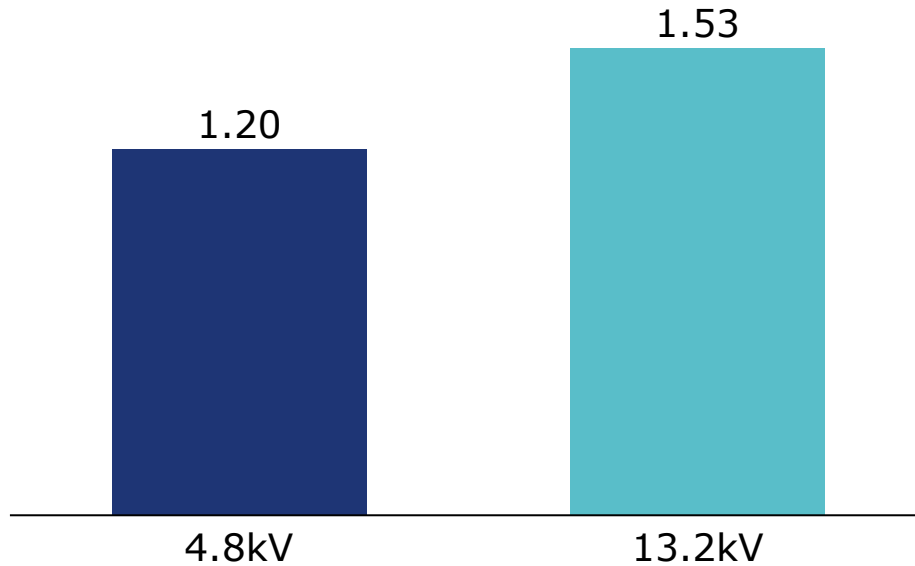

All-weather SAIDI¹
by substation voltage

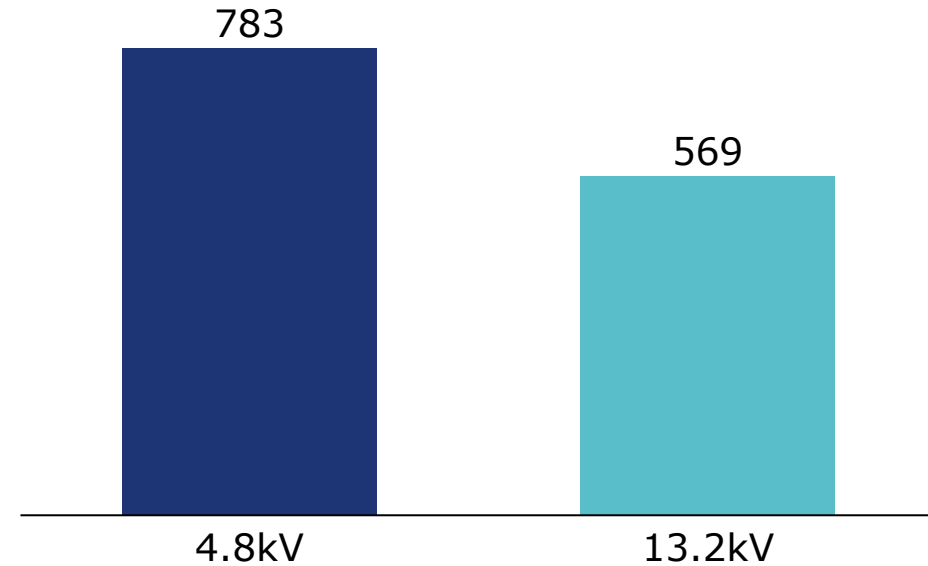

DTE invests in reliability improvements on both 4.8kV and 13.2kV systems to improve safety and reliability

While our 4.8kV and 13.2kV systems have some unique differences, the basic components of the circuit remain the same

Substation

Step down from transmission or subtransmission voltage to primary voltage (4.8kV, 13.2kV)

Cable

Circuits leave substation through conduit and underground (UG) cable

Circuits

- Often come overhead at a pole
- 3-phase backbone, and laterals (primary voltage)
- May be tied together for loop schemes (see box on right side of slide)

URD

Underground residential distribution (URD) – buried looped cable system

Secondary

Lower voltage system on low side of distribution transformers

Loop scheme

The two circuits (red and green) have a point of connection here creating a 'loop'

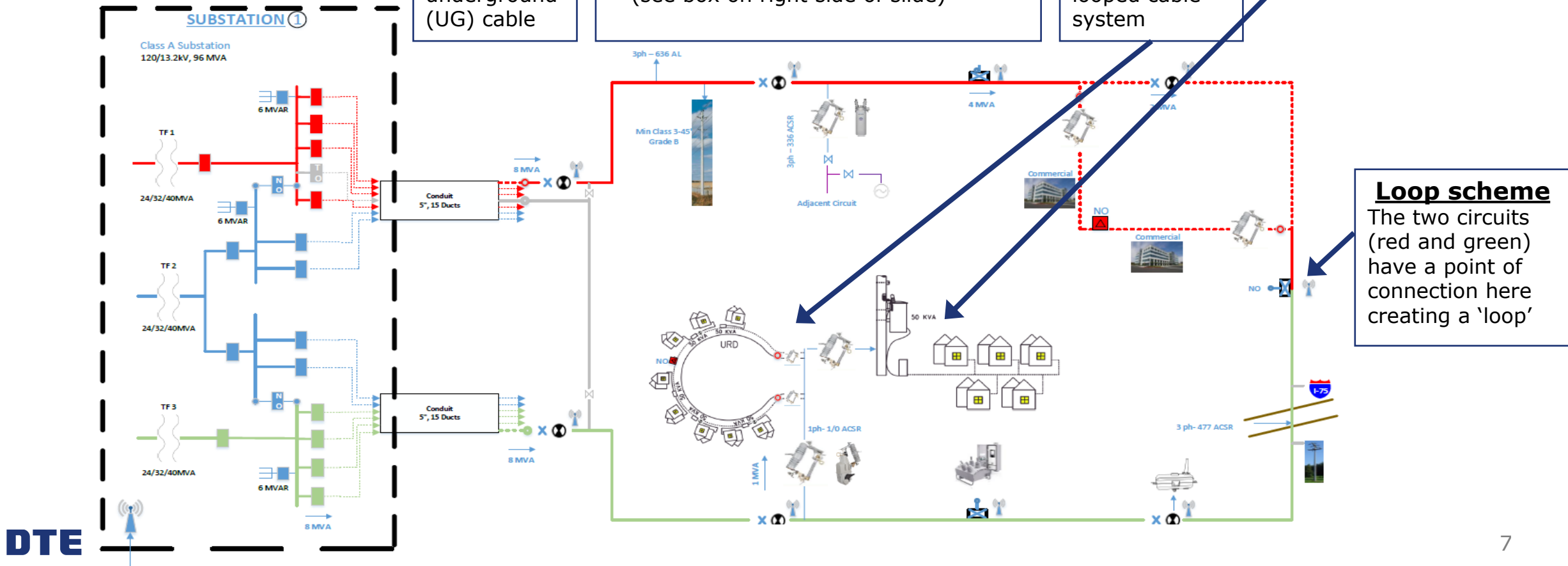

The purpose of a substation is to step down transmission or subtransmission voltages to distribution voltages to serve residential, commercial or industrial loads

Typical Substation Configuration

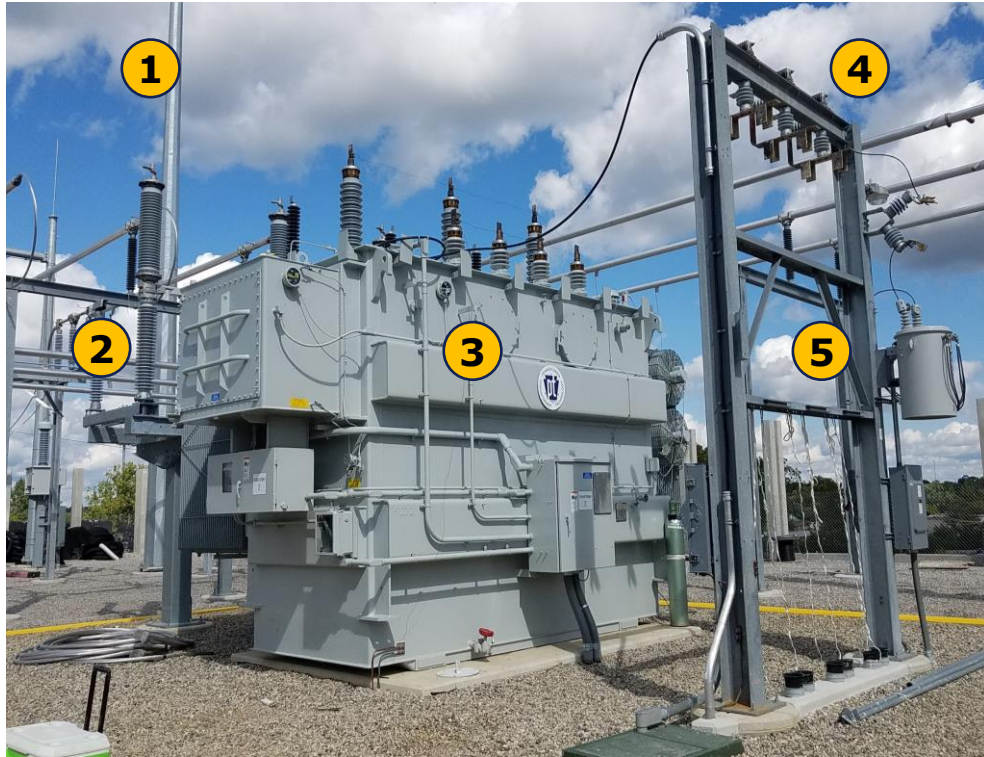

- 1 120kV Input
- 2 Circuit Switcher
- 3 Power Transformer
- 4 13.2kV Output
- 5 Secondary Tower



Number of substations

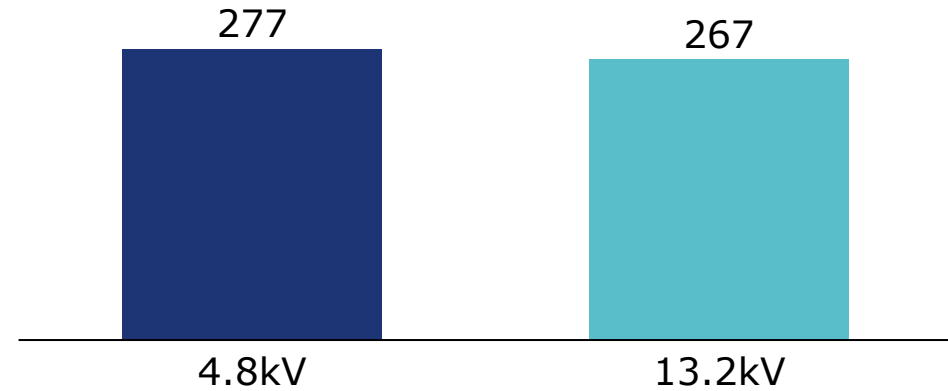

Customers per substation

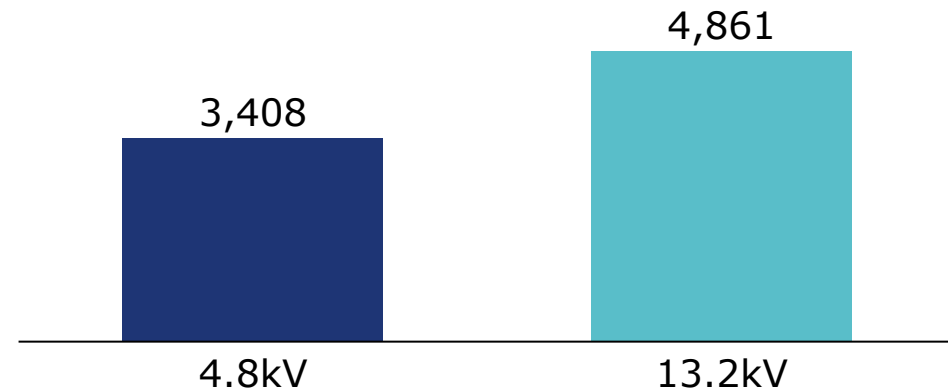

While age is only one factor influencing system performance, our 4.8kV equipment is significantly older on average than equipment on the 13.2kV system

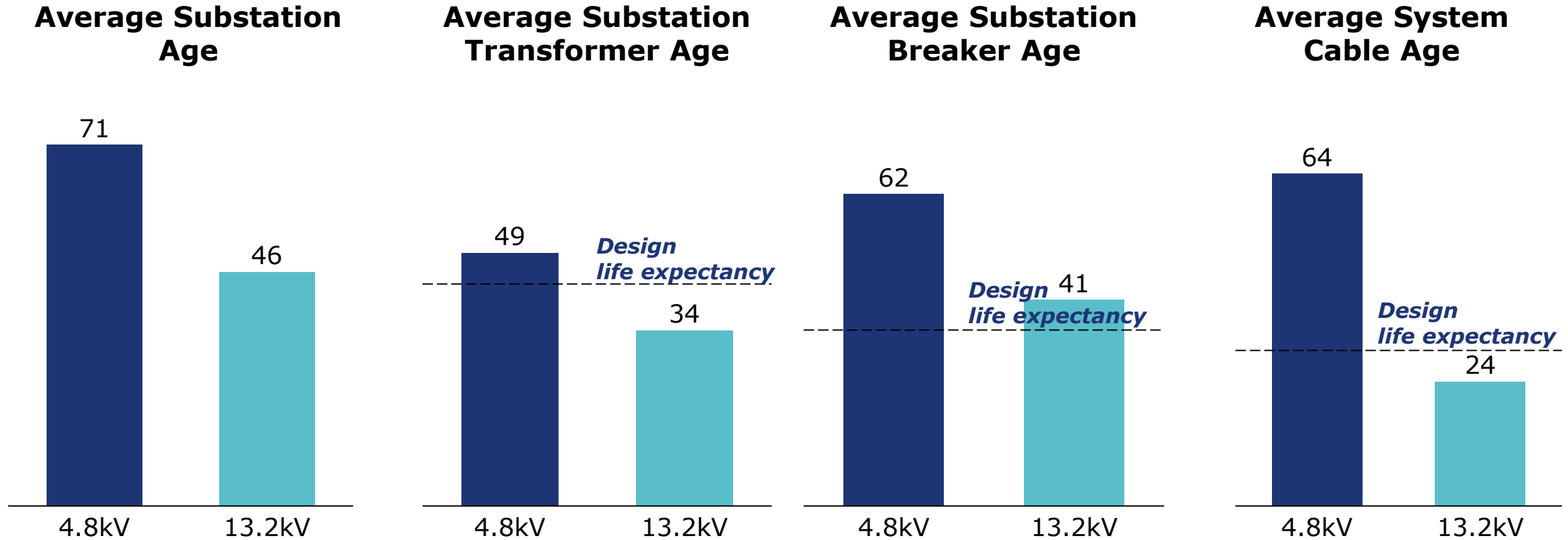

About 35% of our system is underground and primarily uses two main types of cable – System Cable and Underground Residential Distribution (URD) cable



System Cable miles by voltage class

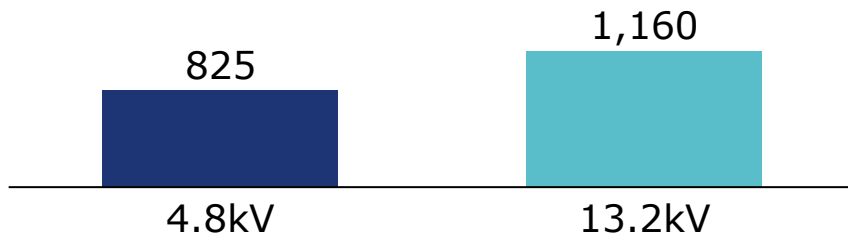

- Most frequently used leaving substation underground regardless of voltage
- Pulled through conduit (duct banks)



URD miles by voltage class

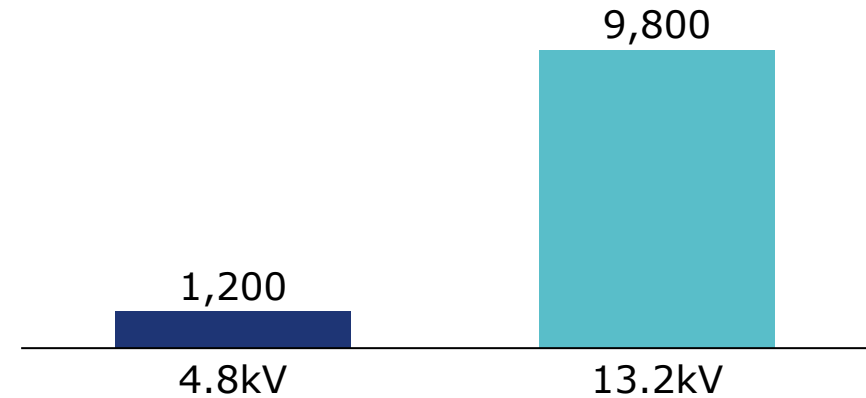

- Direct buried cable in residential subdivisions between transformers
- All new subdivisions since 1970s are fed by URD
- Even when served from a URD, often part of the circuit is fed from the overhead

The most visible part of the distribution system has ~28,500 miles of overhead circuits with, 16,700 miles operating at 4.8kV



Overhead Circuit Miles

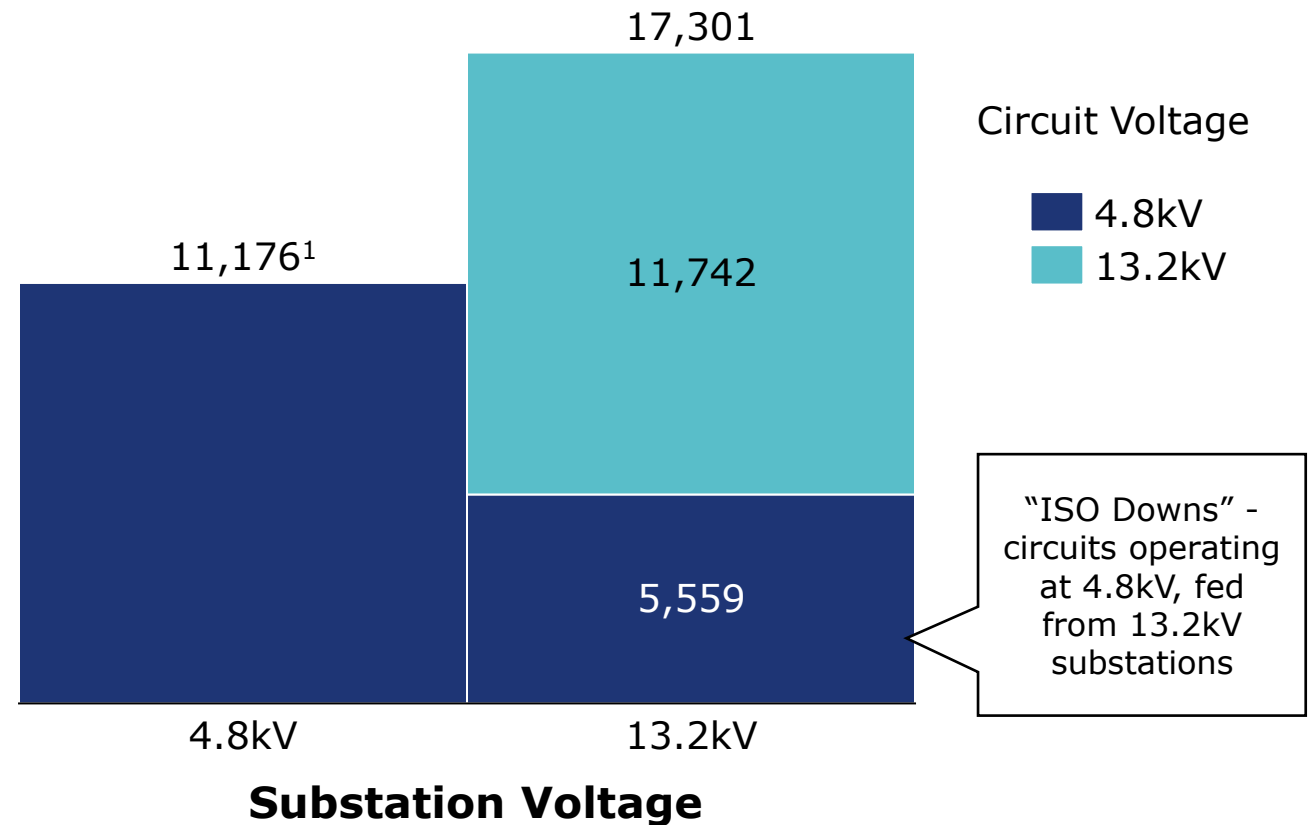

Construction of the three phase leads are similar across voltage type, and may be either in the rear lot or near road right of way; 4.8kV poles are often shorter and require less clearance

4.8kV System



Rear Lot

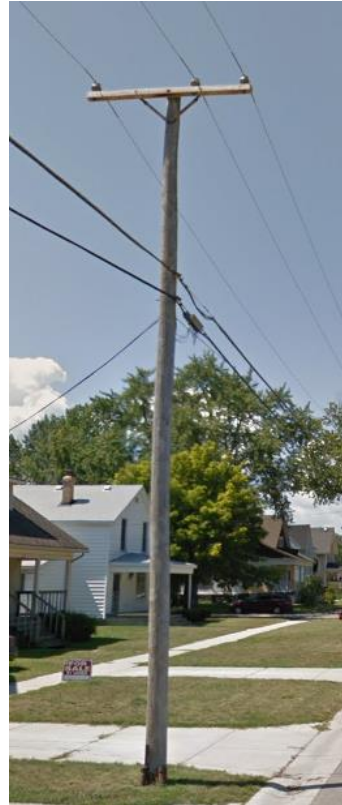

Road right-of-way

13.2kV System



Rear Lot



Road right-of-way

13.2kV circuits can serve up to three times the load of a comparable 4.8kV circuit. DTE Design Standards limit load on a circuit to maintain system capacity and operational flexibility



4.8kV Circuit Loading (MVA)

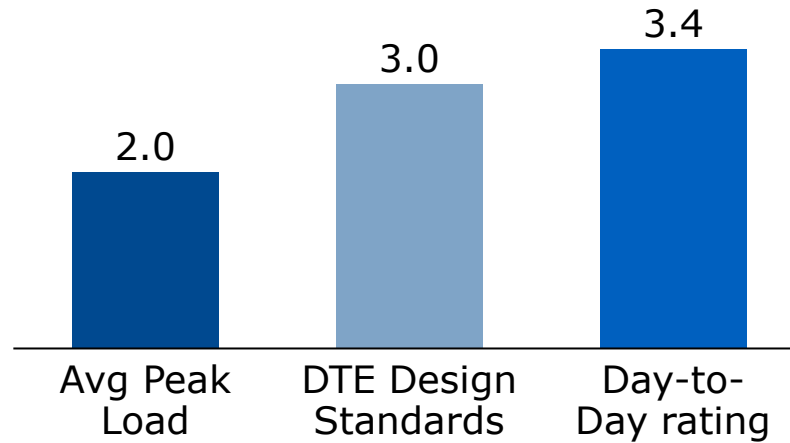

13.2kV Circuit Loading (MVA)

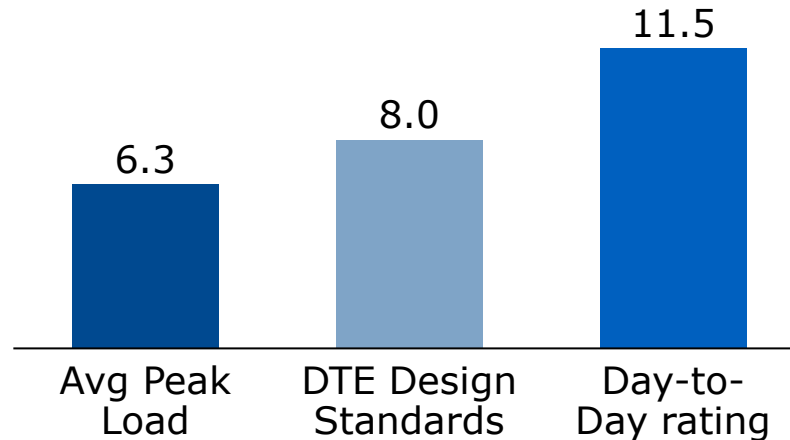

- The day-to-day rating is the load that equipment can operate at without impacting lifespan
- The DTE Design standards limit of 8 MVA is intended to provide capacity to support ~1/2 of an adjacent circuit and remain within the day-to-day rating of the equipment
- Approximately 20% of 4.8kV circuits and 30% of 13.2kV circuits operate above the DTE Design Standards limit

Despite the 4.8kV's superior SAIFI performance, the nature of our 4.8kV system introduces challenges impacting Safety, Reliability, Capacity, Outage Duration, and the ability to add Automation

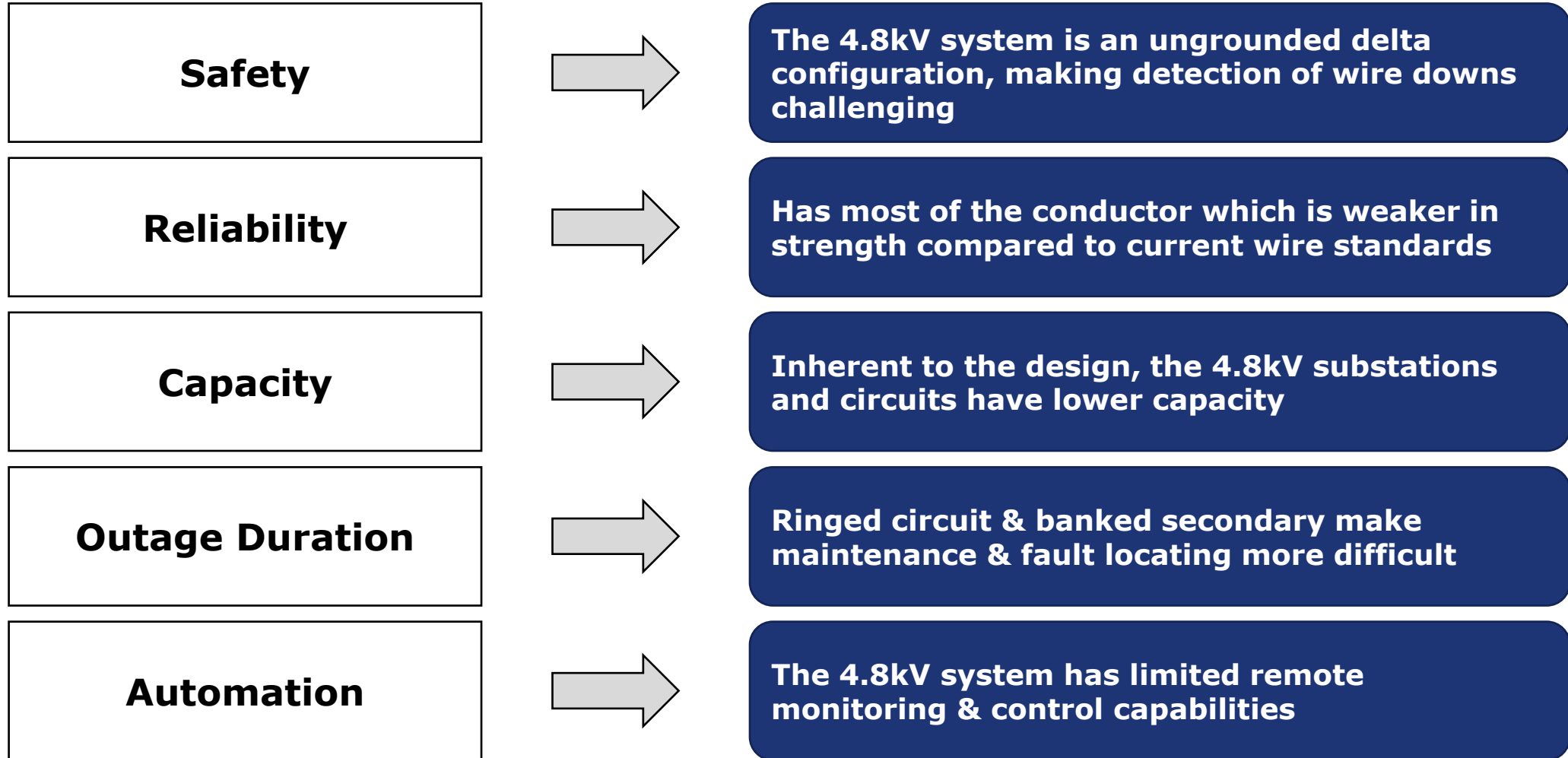

The 4.8kV ungrounded delta configuration leads to low fault currents from wire-downs that don't result in a protective device operating and makes wire-down detection challenging

Ground Fault on 4.8kV Ungrounded Delta

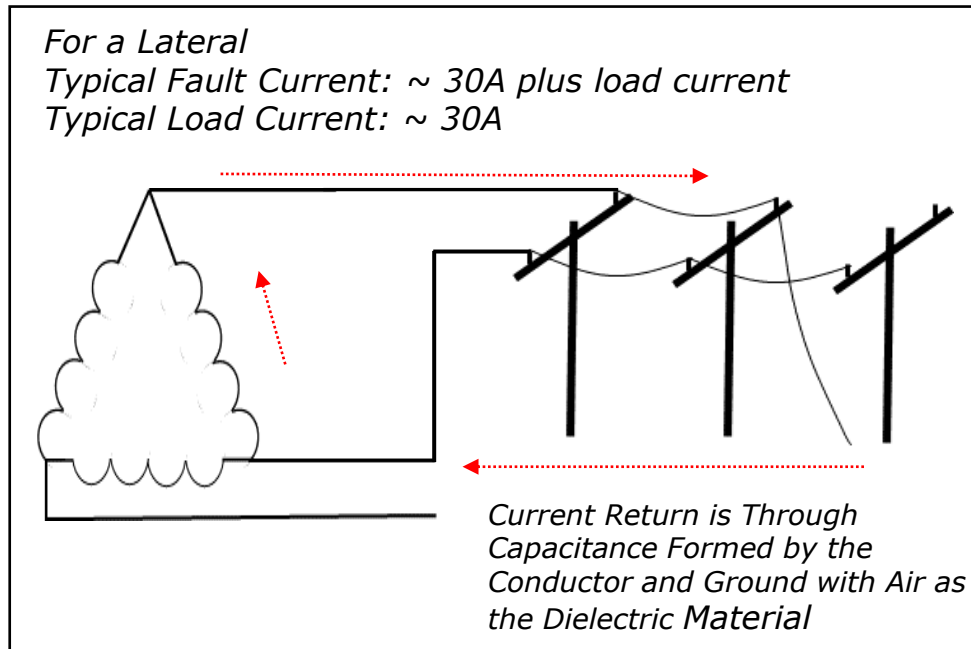

- There is no direct ground path on a delta configuration – and downed wires may only create a fault current that is not much larger than typical loads
- Due to lower fault currents, down wires are typically live
- 80% of the faults are phase-to-ground, which include wire downs
- The remaining 20% are phase-to-phase faults, which create significantly more fault current and trip protective devices typically
- Because protective devices don't operate as frequently, SAIFI performance is superior to a grounded system (13.2kV)

Today's Agenda

- Conference kickoff (15 min)
- Context and background
 - Overview of DTE's 4.8kV distribution system (45 min)
 - **4.8/13.2kV distribution systems and the integration of EVs and DERs (15 min)**
 - The Detroit 4.8kV System and PLD arc wire (15 min with Hardening)
- 4.8kV Hardening Program (45 min)
- 4.8kV Hardening program and alternative solutions (1 hr)
- Open table discussion/conference feedback (30 min)

4.8kV is more susceptible to voltage fluctuations from large electric loads coming on and off the system; future EV and DER additions are expected to exacerbate this issue

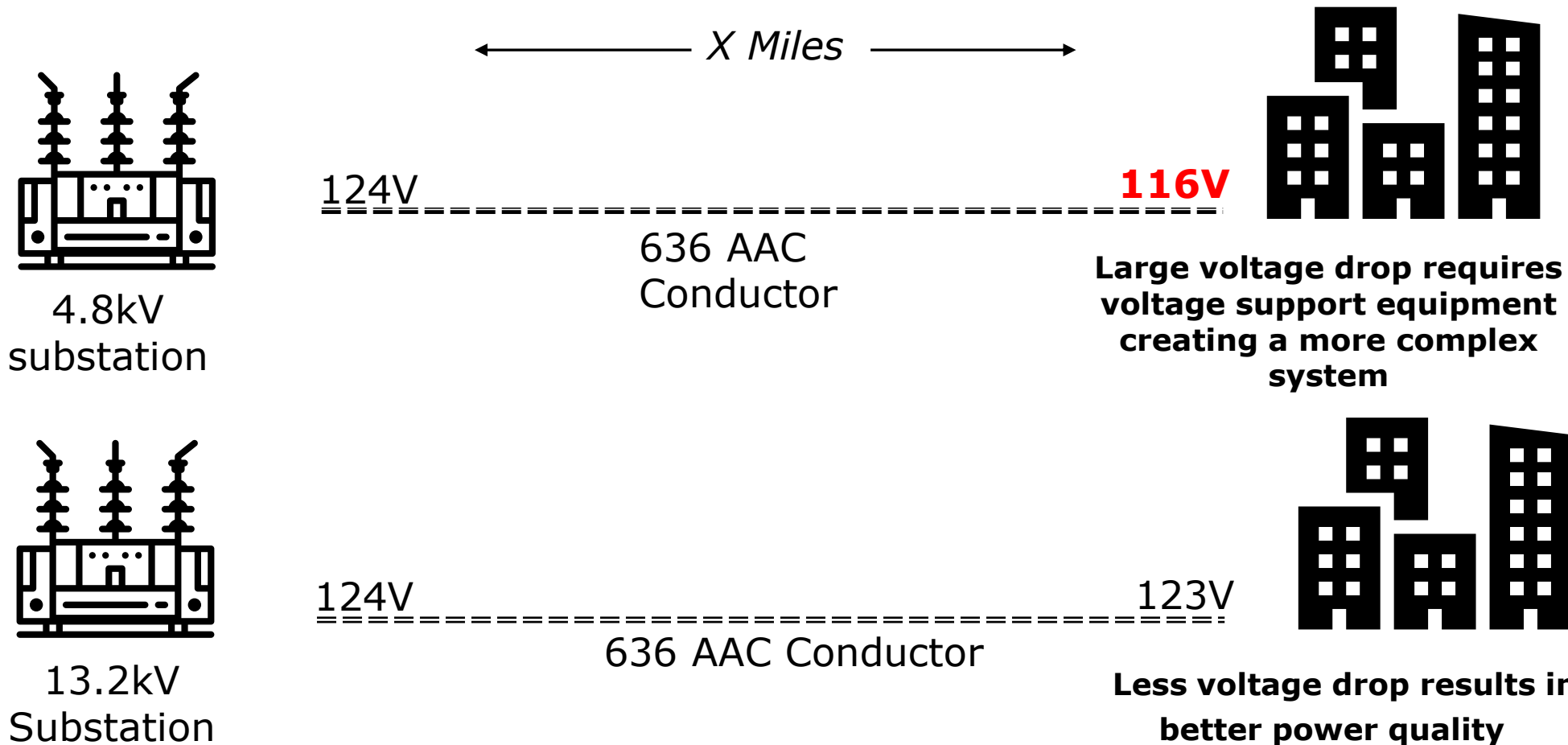

In addition to the voltage concerns, the 4.8kV system will be more challenged to serve future commercial DER and EV's due to limited capacity

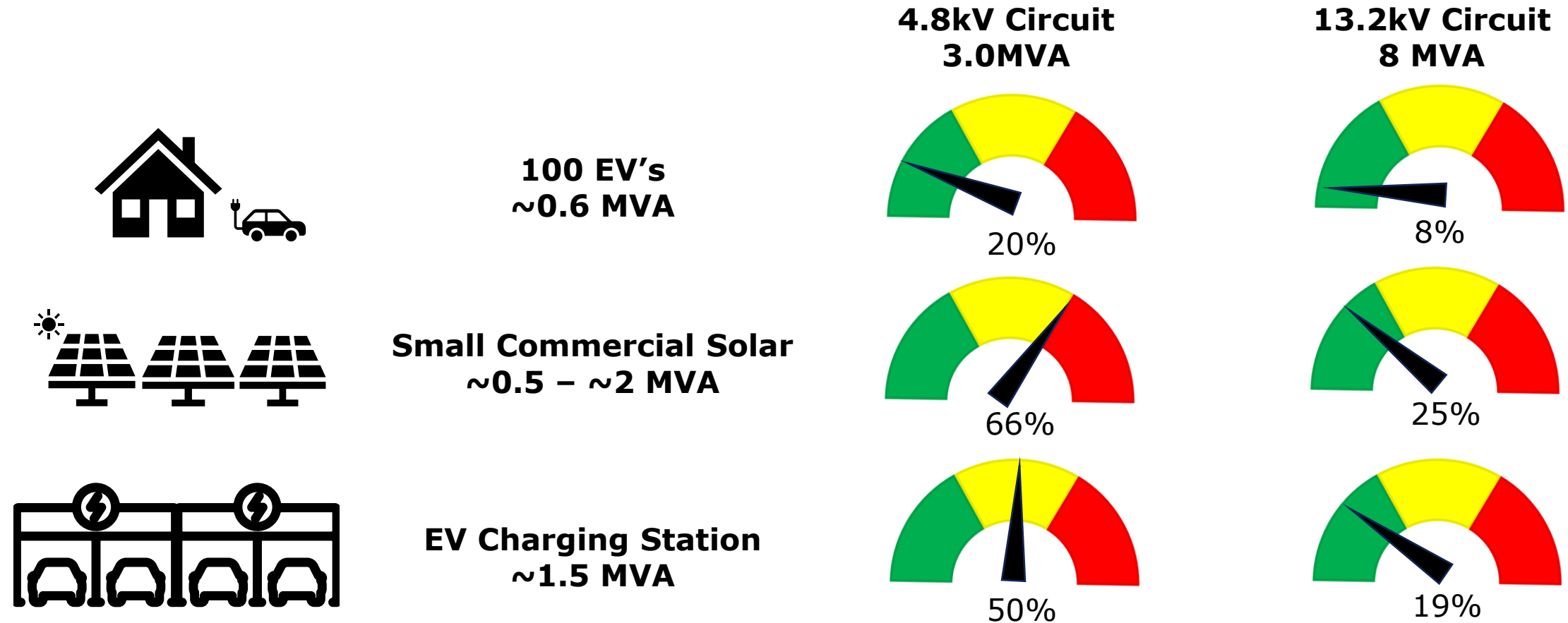

EV and DER on their own can require a majority of circuit capacity on a 4.8kV circuit making it a challenge to serve

Today's Agenda

- Conference kickoff (15 min)
- Context and background
 - Overview of DTE's 4.8kV distribution system (45 min)
 - 4.8/13.2kV distribution systems and the integration of EVs and DERs (15 min)
 - **The Detroit 4.8kV System and PLD arc wire (15 min with Hardening)**
- 4.8kV Hardening Program (45 min)
- 4.8kV Hardening program and alternative solutions (1 hr)
- Open table discussion/conference feedback (30 min)

The age of and access to the 4.8kV infrastructure in the City of Detroit provides significant challenges to maintenance and reliability programs

- The 4.8kV system in the City of Detroit has approximately 2,400 primary overhead line miles
- The electrical system in much of Detroit is the original distribution built and many sections were constructed in the early 1900s
- When installed, back lot construction was prudent
 - Access for DTE construction, maintenance, and tree trimming was through the city-maintained alleyway
 - Over time, the city abandoned alleys and their maintenance which became inaccessible by truck as trees were overgrown or property owners relocated their fence lines
- While much of this construction provided safe and reliable service for decades, the age of the infrastructure, as well as the construction type (size and strength of wire and poles, etc.), no longer provides the level of service the community needs



Michigan Public Service Commission
DTE Electric Company

The Public Lighting Department (PLD) Arc Wire System was used to supply electricity to arc-type streetlamps and share utility poles with DTE Electric distribution

Arc Wire



- Those streetlamps are no longer used, but large amounts of arc wires are still attached to utility poles
- The abandoned wire poses a risk if it becomes energized by making contact with DTE facilities
- In 2017, we estimated that there were approximately 1,300 miles of DPLD arc wire that was intermittently co-located among DTE Electric's 2,400 miles
- An average DTE Electric circuit in the City of Detroit is expected to have arc wire co-located on about 50% of the poles

Today's Agenda

- Conference kickoff (15 min)
- Context and background
 - Overview of DTE's 4.8kV distribution system (45 min)
 - 4.8/13.2kV distribution systems and the integration of EVs and DERs (15 min)
 - The Detroit 4.8kV System and PLD arc wire (15 min with Hardening)
- **4.8kV Hardening Program (45 min)**
- 4.8kV Hardening program and alternative solutions (1 hr)
- Open table discussion/conference feedback (30 min)

In December 2017, the Commission issued an order for DTE to work with Detroit Public Lighting to remove unused arc wire co-located on its infrastructure

- The Order in Case No. U-18484, required DTE to work with relevant entities to accomplish a long-term comprehensive plan to address out-of-service Detroit Public Lighting Department owned arc wire
- The Company closely examined the options to best address the issue and concluded that addressing the DPLD arc wire as a standalone program was not the option that best addressed the safety and reliability needs of the grid
- In response, the 4.8kV Hardening program was developed that balanced safety, cost, and reliability improvements



NEWS RELEASE

Rick Snyder, Governor
Sally Talberg, Chairman
Norm Saari, Commissioner
Rachael Eubanks, Commissioner

Contact: [Nick Assendelft](mailto:Nick.Assendelft@mpsc.com)
517-284-8300 (office)
517-388-3135 (cell)
Customer Support: 800-292-9555
www.michigan.gov/mpsc

FOR IMMEDIATE RELEASE

Dec. 7, 2017

MPSC orders DTE Electric to work with Detroit's lighting department on plan to remove unused power lines

LANSING, Mich. – The Michigan Public Service Commission (MPSC) today called for a comprehensive, long-term plan to document and remove miles of out-of-service power lines in Detroit. The request came as the Commission closed its investigation into the accidental electrocution of a 12-year-old girl in September 2016.

The Commission ordered DTE Electric (DTE) to coordinate with Commission Staff, and the Detroit Public Lighting Department (PLD) to identify the scope of the problem of unused arc lines. The assessment is to include determining how much arc wire remains, who owns the lines and the poles to which they're attached, and accessibility to the wires. The wires powered arc-type street lights, which have not been used for years.

The PLD estimates there is at least 600-900 miles of out-of-service arc wires in its service area, which includes all of Detroit and some outlying areas.

The wiring report is due to the Commission by March 30, 2018, in a new docket (Case No. U-18484). It is to include cost projections, prioritization of work, and how line removal fits into DTE's grid modernizations efforts.

According to DTE's [investigation](#), the city's abandoned arc wire became energized when it came in contact with DTE Electric facilities.

In its review of the incident ([Case No. U-18172](#) and U-18484), the MPSC said that DTE and PLD have improved communication and response times regarding downed wires in the city, and have worked together on two successful pilot programs that removed more than 140,000 feet of abandoned electric lines.

In other MPSC action:

Michigan Gas customers to see lower bills: Michigan Gas Utilities Corp.'s energy waste reduction plan (EWR) and surcharges were approved by the Commission (Case No. U-18269). Under a settlement agreement, residential customers using an average of 10,000 cubic feet of natural gas per month will see a decrease in their bills of 14 cents, beginning in January. Under

The 4.8kV Hardening Program was created to complete a long-term comprehensive plan to address the removal of arc wire while at the same time providing additional safety and reliability benefits

Objectives

- Remove Detroit Public Lighting Department (PLD) arc wire and distribution wire
- Harden and stabilize the 4.8 kV distribution circuits to improve safety, reliability, and storm resiliency
- Extend the life of the 4.8 kV circuits until DTE completes conversion

Scope of Work

- Replace or reinforce condemned poles
- Replace wood crossarms with fiber glass
- Remove Detroit PLD arc wires and distribution wires that are co-located with DTE assets
- Remove service lines to abandoned properties
- Trim the trees to construction specifications

Before Hardening

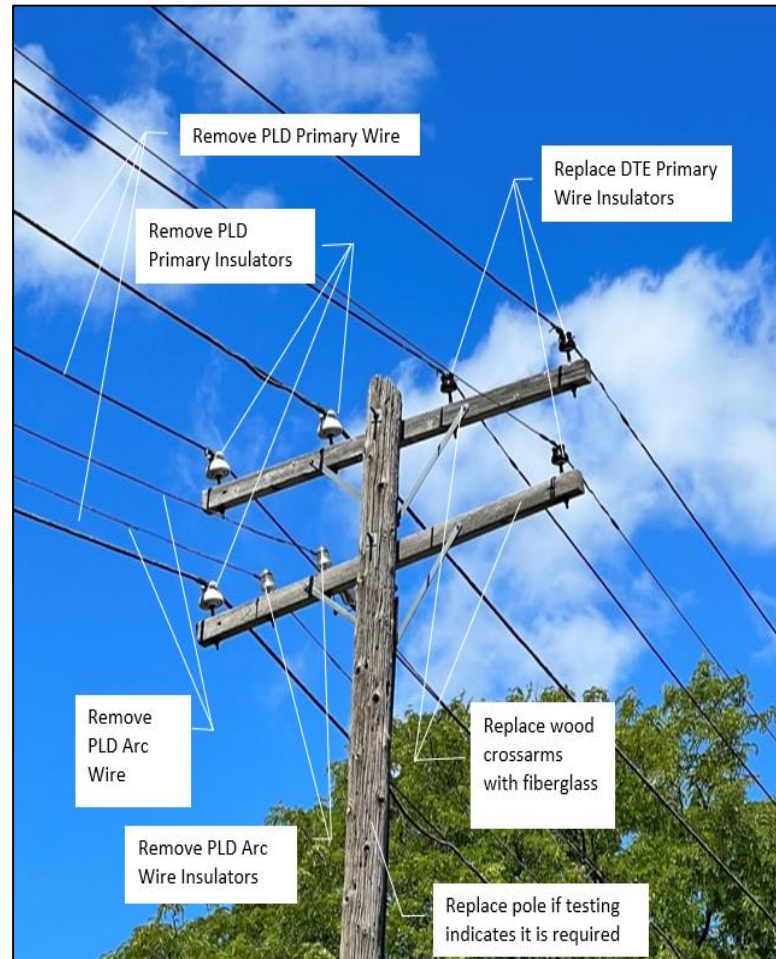

After Hardening



4.8kV Hardening Program Overview - Video



Since 2018, the 4.8kV Hardening Program had addressed ~185 circuits impacting over 144K customers in the City of Detroit and surrounding areas and, by the end of 2023, will have removed over 700 miles of arc wire

4.8kV Miles Hardened
~1,465 miles total

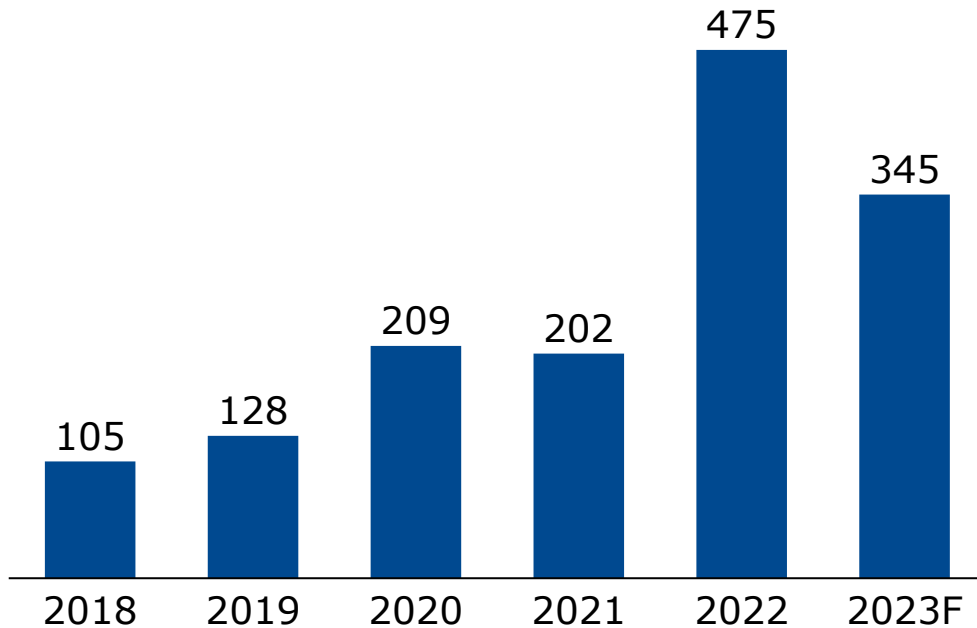

Miles of Arc Wire Removed
~700 miles total

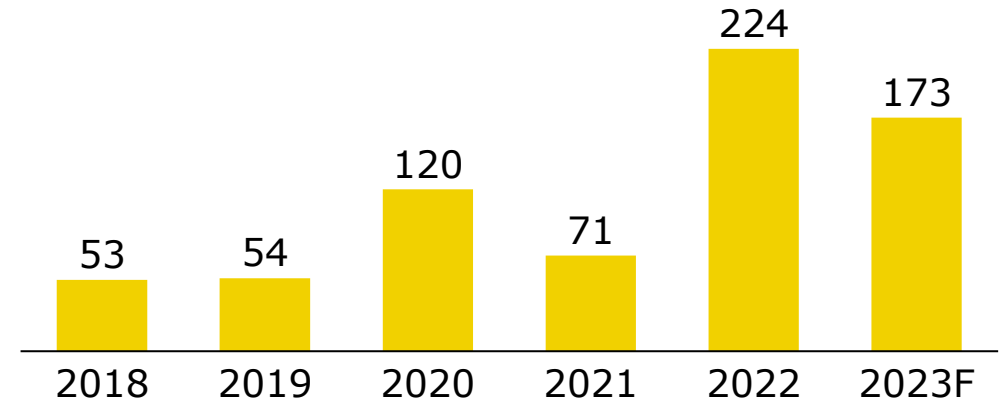

Through 2023 we estimate that we will have removed over half of the arc wire that is co-located with DTE owned assets, and estimates that 400-600 miles of arc wire remain

Performance of circuits addressed by the 4.8kV Hardening program have seen significant improvements in SAIFI, SAIDI ex-MEDs, and wire down events

All Weather SAIFI

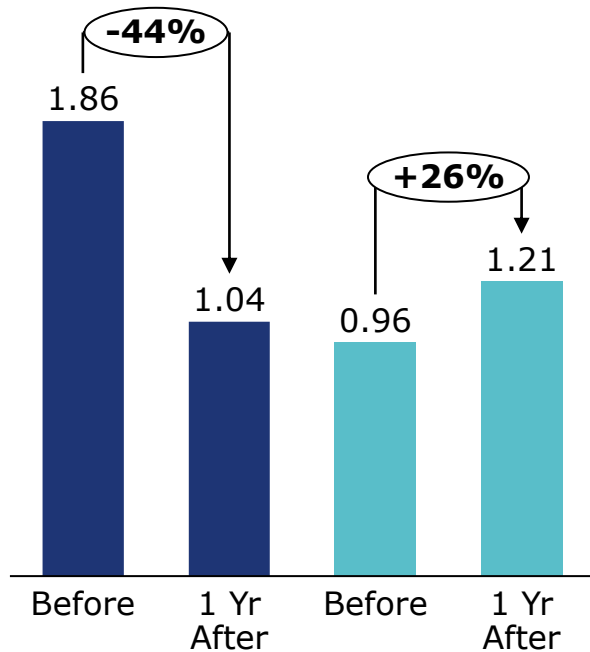

SAIDI ex-MEDs (min)

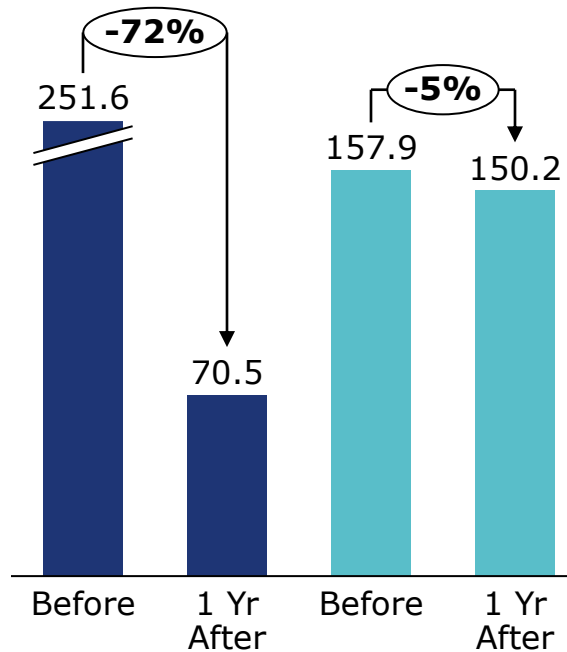

Wire Down Events

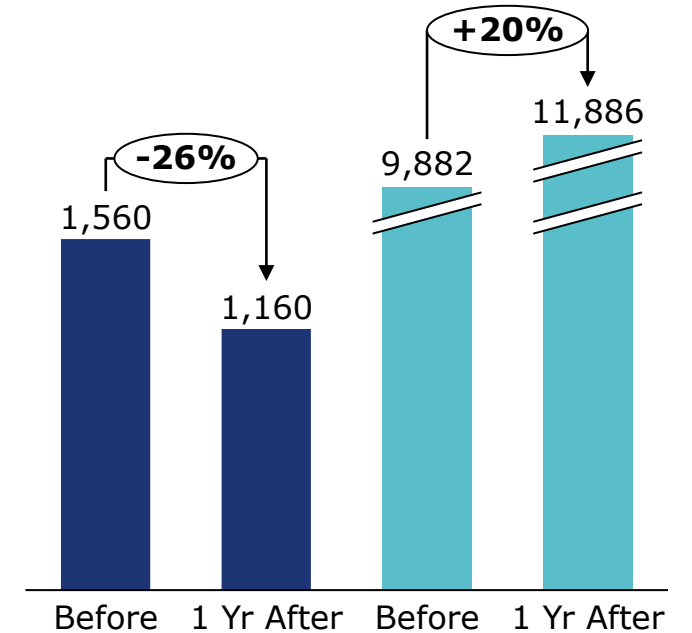

■ 4.8kV Hardened Circuits ■ Control Group

Today's Agenda

- Conference kickoff (15 min)
- Context and background
 - Overview of DTE's 4.8kV distribution system (45 min)
 - 4.8/13.2kV distribution systems and the integration of EVs and DERs (15 min)
 - The Detroit 4.8kV System and PLD arc wire (15 min with Hardening)
- 4.8kV Hardening Program (45 min)
- **4.8kV Hardening program and alternative solutions (1 hr)**
- Open table discussion/conference feedback (30 min)

As directed by the Commission in case U-20836, DTE has considered several alternatives to the 4.8kV Hardening program

Tree Trimming

- Trees trimmed to enhanced specification, no arc wire removal

PTMM

- Replace failed poles and pole top equipment, no arc wire removal

Arc Wire Removal

- Arc wire removal only, reduced scope tree trimming and equipment replacement

4.8kV Hardening

- Arc wire removed, crossarms replaced, tree trimming

Pre-conversion

- Arc wire removed, rebuild wires, poles, and pole tops to 13.2kV standards

Conversion

- Fully convert circuit and substation to 13.2kV, includes automation

Microgrids

- Arc wire removed with pre-conversion and microgrid for reliability

DERs

- Utility-scale or distributed solar and storage to improve capacity

Energy Efficiency

- Target residential, commercial, and industrial customers for waste reduction

Storage

- Utility-scale battery storage to improve capacity by shifting/decreasing peak

When comparing the effectiveness of the various alternatives, five approaches were appropriate for addressing the removal of the PLD arc wire

		Arc Wire Removal	Improved Reliability	Improved Safety/ Wire down	Improved Capacity	Cost Level	Execution Complexity
						Low	Low
						Low	Low
Selected for Consideration	1					Medium	Low
	2					Medium	Low
	3					High	Medium
	4					High	High
	5					Very High	Very High
						Medium	Medium
						Low	Medium
						High	Medium

Increasing difficulty

1 Arc Wire Removal Only: While there are benefits to only removing the arc wire, this option overlooks the opportunity to significantly improve the safety and reliability for the entire circuits that contain arc wire

 Execution Speed: High

Scope – Arc Wire removal only

Cost per mile: \$175K - \$207K

- Remove Detroit Public Lighting Department (PLD) arc wire
- Trim the trees as needed to identify/remove the arc wire
- Balance the cross arms to make safe (for poles with arc wire, vast majority of cross arms will need to be replaced)
- Replace/reinforce pole if necessary
- Replace pole top if necessary

Benefits

- Remove Detroit Public Lighting Department (PLD) arc wire
- Improved reliability:
 - Wire down – 13% improvement
 - SAIFI – 22% improvement
 - SAIDI – 36% improvement
- Arc wire removal only is ~55% of the cost of Hardening per mile and best-case scenario results in half the reliability benefits

~50% of 4.8kV circuit miles will not receive reliability benefits under this program

2 4.8kV Hardening: By conducting 4.8 kV Hardening on circuits that contain arc wire, customers experience significantly improved reliability and safety across the entirety of the circuit

 **Execution Speed: Medium-High**

Scope – 4.8kV Hardening

Cost per mile: \$333K - \$373K

- Remove Detroit PLD arc wires and distribution wires that are co-located with DTE assets
- Trim the trees to construction specifications
- Perform pole testing and replace or reinforce condemned poles
- Replace wood crossarms with fiber glass crossarms
- Remove service lines to abandoned properties

Benefits

- Remove Detroit Public Lighting Department (PLD) arc wire
- Harden and stabilize the 4.8kV distribution circuits
- Extend the life of the 4.8kV circuits
- Improved reliability:
 - Wire down – 26% improvement
 - SAIFI – 44% improvement
 - SAIDI – 72% improvement

3 Pre-conversion: Brings the OH portion of the circuit up to new 13.2kV standards while leaving the UG and substation unchanged; this delivers tremendous reliability and safety benefits but does not add the additional capacity of full conversion

 Execution Speed: Medium-Low

Scope – Pre-conversion

Cost per mile: \$1.4M - \$2.0M

- Remove Detroit PLD arc wires and distribution wires that are co-located with DTE assets
- Trim the trees to construction specifications
- Rebuild pole tops using fiberglass cross arms
- Replace poles and transformers as needed
- Reconductor overhead lines as needed, install neutral wire
- Rebuild underground infrastructure as needed

Benefits

- Replaced equipment meets latest upgraded standards
- Prepares the overhead infrastructure for conversion to 13.2kV
- Improved reliability
 - Wire down – 90% improvement
 - SAIFI – 85% improvement
 - SAIDI – 85% improvement



Michigan Public Service Commission
Docket No. 2019-001-CP

4 **Conversion:** Complete rebuild of the all parts of the substation and circuit yielding safety, reliability, and capacity benefits

Execution Speed: Low

Scope – Conversion

Cost per mile: \$2.4M - \$3.0M

- All pre-conversion activities
- Build new 13.2kV sub/expand existing 13.2kV sub and install controls & automation in the substations/circuits to latest design standards
- Establish new DCs from new/upgraded 13.2kV substation
- Reconfigure circuits & establish jumpering points
- Convert and transfer load off the 4.8kV system to the 13.2kV system

Benefits

- Decommissioning of aging equipment
- Increased area capacity
- Reduced overload situations
- Improved jumpering capability
- Automated restoration
- Wye configuration is safer as wire downs are generally de-energized

DTE has several 4.8kV conversion projects underway throughout our service territory, many of which are concentrated in the City of Detroit

DTE Conversion Projects

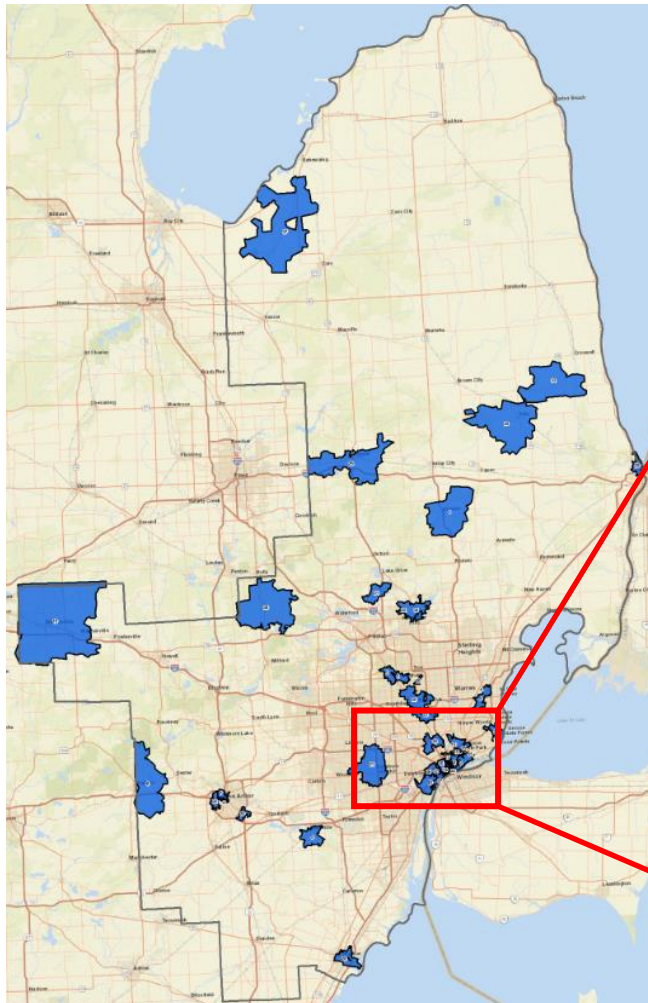

City of Detroit Conversion Projects

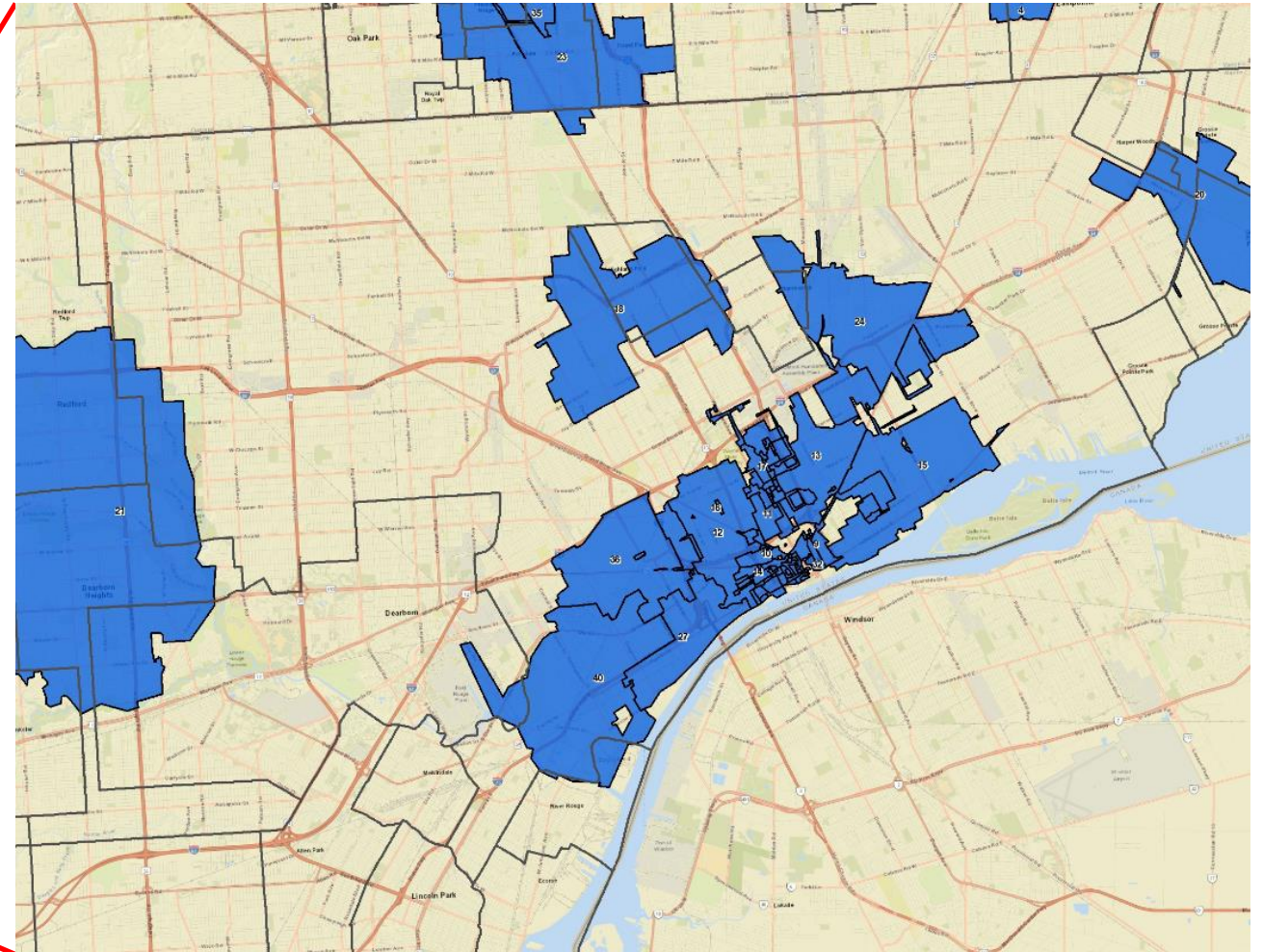

In addition to all the construction work that conversion entails, there are a significant number of challenging activities that must occur to complete the rebuild and voltage conversion of a circuit



- 1 **Property acquisition** can be a long process to identify and purchase the location
- 2 **Permitting and approvals** for easements and environmental clearances for new circuits often have long time horizons
- 3 **Interconnection with ITC** can be lengthy requiring studies and approvals through MISO
- 4 **Customer Communication and Outreach** efforts can be extensive when new construction differs from existing facilities

- 5 **Establishing new circuits** requires significant underground work from the substation impacting adjacent public roads and property
- 6 **Weather constraints** impact the timing of customer shutdowns as they are typically performed in weather above 40 degrees
- 7 **Large scale coordination and overhead resources** are required to change each distribution transformer to the higher voltage simultaneously

5 **Microgrids:** Microgrid customers are likely to experience higher levels of reliability, but installation costs and execution complexity are very high

 Execution Speed: Low

Scope – Microgrids

Cost per mile: \$12.1M - \$17.0M¹

- All pre-conversion
- Install solar and battery storage as dictated by project along with associated equipment (inverters, switchboards, communication gateways, reclosers, etc.)
- Site prep as needed for battery storage (fence, driveway, below grade conduit etc.)

Benefits

- Islanding capability when main grid is not on-line
- Increased reliability from redundant source
- Improved jumpering capability
- Automated restoration
- Improved reliability within the Microgrid²
 - Wire down – 90% improvement
 - SAIFI – 90% improvement
 - SAIDI – 90% improvement

Microgrids can vary significantly based on use case; a key component to microgrids is energy storage³ which is high cost and has a long lead time

¹ Based on Port Austin example using 500kW solar and 1MW x 4MWh battery trailer

² Based on expectations

³. DTE did not consider fossil generation as an energy source for microgrids

- 5 **Microgrids:** One microgrid project is currently in progress in Port Austin; the Company is pursuing additional microgrid projects at Port Austin and O'Shea as part of an IIJA grant

Port Austin Project (Pilot/IIJA Grant)

Current Project:

- Install (1) 500kW solar array
- Install (1) 1MW x 2-4MWh battery storage systems at two separate locations
- Install reclosers, communication and controls to create microgrid

Future Proposals:

- Install two additional microgrids
- All three microgrids will work together to provide optimized reliability for customers

O'Shea Project (Pilot/IIJA Grant)

Current Project:

- Install (1) 1MW x 2-4MWh battery storage system (already owned)

Future proposals:

- Install one more battery storage and other equipment to create two microgrids
- Install reclosers, communication and controls
- The two microgrids will work together to provide optimized reliability for customers

Expected outcomes from these pilots

- Influence the industry's development of the electrical system and advance the deployment of sophisticated and simpler microgrids
- Develop internal DTE Electric expertise with microgrids
- Enhance partnerships with other organizations such as EPRI and DOE National Laboratories
- Progress technology outside the NWA and microgrid space (i.e., fault locating, load forecasting, DER anomaly detection)

When comparing the alternative approaches, the 4.8kV Hardening program was selected originally because it strikes a balance between cost, reliability, and the timely removal of the arc wire from the DTE Electric system

	Cost per mile ¹	Wire down Reduction	SAIFI Reduction ²	CAIDI Reduction ³	Capacity Increase	Increase DER Usage	Execution Complexity	Potential Use Case
Arc Wire Removal	\$191K	13%	22%	36%	No	No	Low	Lowest overall cost to remove arc wire
4.8kV Hardening	\$353K	26%	44%	72%	No	No	Low	Highest benefit/cost for reliability improvement
Pre-conversion	\$1.7M	90%	85%	85%	No	Yes	Medium	Provides step change in reliability performance
Conversion	\$2.7M	90%	85%	85%	Yes	Yes	High	Best benefit/cost for significant capacity needs
Microgrids	\$14.6M	90%	95%	95%	Yes	Yes	Very High	Potentially application for grid areas with critical reliability needs



1. Median of cost range
 2. SAIFI measures the frequency of customer interruptions
 3. CAIFI measures the duration of customer interruptions

Today's Agenda

- Conference kickoff (15 min)
- Context and background
 - Overview of DTE's 4.8kV distribution system (45 min)
 - 4.8/13.2kV distribution systems and the integration of EVs and DERs (15 min)
 - The Detroit 4.8kV System and PLD arc wire (15 min with Hardening)
- 4.8kV Hardening Program (45 min)
- 4.8kV Hardening program and alternative solutions (1 hr)
- **Open table discussion/conference feedback (30 min)**

Discussion / feedback

- Open table discussion
- Conference feedback



BENEFIT-TO-COST ANALYSIS MODELING



POLE AND POLE TOP MAINTENANCE AND MODERNIZATION &
OVERHEAD TO UNDERGROUND CONVERSION PILOTS

SUBMITTED TO
DTE

REVISION 1.0
MARCH 6, 2024

3/6/2024

Benefit-to-Cost Analysis Modeling

CONTENTS

1.0 Introduction.....	3
1.1 Report Overview.....	3
1.2 Benefit-to-Cost Analysis Approach	3
1.3 Interpreting the Model and Business Case Results	4
2.0 Benefit-to-Cost Analysis Models.....	6
2.1 Pole and Pole Top Maintenance and Modernization Model	6
2.2 Overhead to Underground Primary Model	6
2.3 Overhead to Underground Services Model.....	7
3.0 Key Assumptions	8
3.1 Geographical Information System	8
3.2 Event Data	8
3.3 Customer Data	9
3.4 PTMM Specific Information	9
4.0 Benefit-to-Cost Analysis Approach	11
4.1 Financial Assumptions	11
4.2 Upfront Investments	11
4.3 Failure Probability Assumptions	13
4.4 Avoided Life-cycle Costs (Benefits)	15
5.0 Model Results	21
5.1 Pole and Pole Top Maintenance and Modernization Model	21
5.2 Overhead to Underground Primary Model	22
5.3 Overhead to Underground Services Model.....	24

FIGURES

Figure 4-1 DTE’s Asset Weibull Curves	13
Figure 4-2 Annual Probability of Failure Example: 40-Year-Old Wood Pole.....	14
Figure 4-3 Annual Probability of Failure Profiles for Wood Poles	15
Figure 4-4 Michigan Residential DOE ICE Calculator Values	19
Figure 4-5 Michigan Commercial & Industrial DOE ICE Calculator Values	19
Figure 5-1 PTMM BCA Summary.....	21
Figure 5-2 Appoline BCA Results	22
Figure 5-3 Buffalo Charles BCA Results.....	23
Figure 5-4 Generic Overhead Service Results	24

3/6/2024

Benefit-to-Cost Analysis Modeling

TABLES

Table 1-1 Example Business Case Calculations (40-Year Life-cycle Present Value).....	4
Table 3-1 Lateral vs Backbone Pole Classification.....	8
Table 3-2 Outage vs Non-Outage Event Assumptions.....	8
Table 3-3 PTMM Model Customer Impact Assumptions	9
Table 3-4 PTMM Model Outage Customer Impact Example	9
Table 3-5 Estimated PTMM Inspection Results	10
Table 4-1 Financial Assumptions	11
Table 4-2 Unit Cost Assumptions	12
Table 4-3 Inspection Cycle Assumptions	12
Table 4-4 Pilot Cost Assumptions.....	12
Table 4-5 Weibull Parameters for Asset Classes Modeled	13
Table 4-6 Equipment Failure Reactive Cost Assumptions.....	16
Table 4-7 Non-Equipment Outage Reactive Cost.....	16
Table 4-8 Non-Outage Trouble Reactive Event Reduction.....	17
Table 4-9 Customer Outage Duration Assumptions	17
Table 4-10 Wire Down Event Reductions	20

ABBREVIATIONS

<u>Abbreviation</u>	<u>Term/Phrase/Name</u>
BCA	Benefit-to-Cost Analysis
BCR	Benefit-to-Cost Ratio
C&I	Commercial & Industrial
CI	Customers Interrupted
CMI	Customer Minutes Interrupted
DOE	Department of Energy
DTE	DTE Energy
GIS	Geographic Information System
ICE	Interruption Cost Estimator
OH	Overhead
OMS	Outage Management System
PTMM	Pole and Pole Top Maintenance and Modernization
UG	Underground

3/6/2024

Benefit-to-Cost Analysis Modeling

1.0 Introduction

1.1 Report Overview

Recent rate cases have put increasing focus on quantifiable and compelling benefit-to-cost analysis for utility investments. This report provides details regarding the updated benefit-to-cost analysis models that DTE Energy (DTE) is using to support the analysis. The models are designed to evaluate the life-cycle benefits and associated costs for investment options. Each of the models are built to develop a benefit-to-cost analysis that is tailored for each investment option being evaluated. This report presents the results of the analyses, including assumptions, their rationale, and how they are applied.

1.2 Benefit-to-Cost Analysis Approach

The Benefit-to-Cost Analysis (BCA) approach for each model is fundamentally the same. To calculate the benefits of an investment option, it is important to understand the baseline from which those benefits need to be calculated. For each of the models, this scenario is called “Baseline Scenario,” which represents a no investment, run-to-failure scenario. The result is an understanding of how the current assets may perform over the next 40 years, before any proactive investment option is placed in-service.

The model represents one cycle of life for the existing assets and the new assets that would replace them in each of the investment options. The model also incorporates the asset risk, including future reactive costs, for existing and new assets. This allows appropriate comparisons of doing nothing versus choosing an investment option today, playing those situations out into the future over the same time window, and comparing the results. The BCA approach is designed to align incremental costs with expected incremental benefits. However, it is important to recognize the inherent limitations of this modeling approach since it does not include the financial valuation of very important considerations such as safety and resiliency benefits of these investments.

The use of the BCA models outlined in this report represents one of the many tools that DTE utilizes in its investment planning journey. While a benefit-to-cost analysis is not the only driver for how a utility should use investment dollars, it is nonetheless an important consideration when it comes to prioritizing work, optimizing investment, and communicating the value of one investment option versus another. There is a myriad of other factors that drive investment option needs and timing, such as regulatory mandates, public and employee safety, labor and materials availability, and unplanned failures, to name a few. The benefit-to-cost analyses utilized here by DTE contain many of the underlying principles that form the basis for similar distribution investments requested by commissions and used by utilities across the country. Here are some of the key principles:

- **Customer-Centric:** For distribution investment options, external stakeholders are keen to understand how projects are expected to impact reliability. The quantified benefits are shown from the customer’s perspective by calculating the avoided reactive costs, cyclical program costs and avoided customer outages. All quantified business case results include these metrics.
- **Data as the Foundation:** The models utilize DTE’s geographic information system (GIS), outage management system (OMS), and customer/circuit database.
- **Asset-Centric:** The BCA models are built using a bottom-up approach, incorporating what is known about the existing infrastructure as well as what assets will be in place after a project is completed.
- **Consistency:** The models calculate the benefits using a consistent framework for all investment options.

3/6/2024

Benefit-to-Cost Analysis Modeling

With that said, there are a few key considerations that the reviewers should take note of when examining the BCA model results:

- Absence of safety benefits in the quantifiable benefit cost ratio; yet safety is one of the key drivers for many strategic investment decisions for electric distribution utilities.
- Lack of full considerations on resiliency values of the investment options, or the benefit of the investments during catastrophic events, as the models take on an average, deterministic approach on outage duration.
- Conservative assumptions on customer cost of interruption as the current ICE calculator does not fully capture the increased trends in society’s use of technology in the last 10-15 years.

As a result, the benefit cost ratios presented in the whitepaper for both the PTMM program, and undergrounding pilots are conservative and define the lower bound of the customer values delivered by the investment options.

Ultimately, to address these considerations, additional research and analysis need to be performed. Like many other analytical models, the BCA models will continue to evolve and be enhanced as DTE collects more data and makes further refinements on the analytical approach.

1.3 Interpreting the Model and Business Case Results

The outputs of the models are the life-cycle risk-weighted present value of each investment option and the benefit-to-cost ratio (BCR). This allows different investment options to be evaluated using the same analytical framework. Table 1-1 shows an example of the business case evaluation. Note, further explanation on the cost items included in the table are provided in Section 4.0.

Table 1-1 Example Business Case Calculations (40-Year Life-cycle Present Value)

	Baseline Scenario	Example Investment Option
Initial Investment Option Investment	\$0	\$520,000
Equipment Failure Reactive Cost	\$325,000	\$30,000
Non-Equipment Outage Reactive Cost	\$125,000	\$20,000
Non-Outage Trouble Reactive Cost	\$25,000	\$15,000
Emergent Reactive Cost Total	\$475,000	\$65,000
Customer Outage Cost (ICE)	\$195,000	\$20,000
Vegetation Management Cost	\$50,000	\$50,000
Total Life-Cycle Cost Excluding Initial Investment	\$720,000	\$135,000
Benefit (Avoided Cost)	\$720,000 - \$135,000 = \$585,000	
Benefit-to-Cost Ratio for Example Investment Option	\$585,000 / \$520,000 = 1.125	

3/6/2024

Benefit-to-Cost Analysis Modeling

As shown in the table above, the initial investment in the example investment option totaled \$520,000 and the resulting benefit is \$585,000. Taking the benefits divided by the costs, the BCR is 1.125. This investment option has benefits that outweigh the cost, illustrating that it is a prudent investment.

3/6/2024

Benefit-to-Cost Analysis Modeling

2.0 Benefit-to-Cost Analysis Models

The BCA models calculate a life-cycle present value of the investment options by evaluating the benefits and costs of investing in Pole and Pole Top Maintenance and Modernization (PTMM) and overhead to underground conversion pilots. The models estimate the investments required for the investment options and the resulting benefits over the next 40 years. The result of this analysis is a data-driven BCR, useful for identifying and prioritizing value-adding investment options. Here are the models presented in this report:

Benefits are calculated as the difference in life-cycle cost between the investment option and the Baseline Scenario (i.e., avoided costs)

- **Pole and Pole Top Maintenance & Modernization:** Evaluates the PTMM program across DTE’s distribution circuits.
- **Overhead to Underground Primary:** Evaluates the undergrounding investments for Appoline (construction completed) and Buffalo Charles (construction in-flight) projects.
- **Overhead to Underground Services:** Generic evaluation of undergrounding existing overhead services

2.1 Pole and Pole Top Maintenance and Modernization Model

The PTMM model’s objective is to provide a quantitative benefit-to-cost analysis for the Pole and Pole Top Maintenance and Modernization program at DTE. The model utilizes a long-term, net present value methodology to develop a 40-year calculation of present value for costs and benefits. The model scope includes all the distribution circuits that have overhead segments. For each circuit, the analysis includes the benefits and costs of performing one cycle of inspections, reinforcements, and/or replacements. The PTMM model provides a data-driven benefit-to-cost ratio for each circuit that illustrates the business case for performing PTMM.

2.2 Overhead to Underground Primary Model

The objective of the Overhead to Underground Primary model is to develop a quantitative benefit-to-cost analysis for two overhead-to-underground conversion pilots. Specifically, the model is built to analyze the Appoline and Buffalo Charles pilots and is not configured to be universally applied to other projects. The model utilizes a long-term, net present value methodology to compare the costs associated with investment options to their benefits. For this model, multiple investment options are evaluated. The investment options are summarized below:

- **Baseline Scenario** - Continued operation of this section of the system with a run-to-failure approach.
- **PTMM Only** - Incorporating the existing overhead assets into the PTMM program and no other proactive replacement of the assets.
- **Overhead Rebuild** - Rebuilding the section of the system to current overhead standards. This investment option also includes committing to future PTMM program investment.
- **Overhead to Underground** - Converting the overhead assets to underground.

Additional details of the model are described in subsequent sections of this report.

3/6/2024

Benefit-to-Cost Analysis Modeling

2.3 Overhead to Underground Services Model

The Overhead to Underground Services model develops a quantitative benefit-to-cost analysis for undergrounding existing overhead services. The Overhead to Underground Services model is configured similarly as the Overhead to Underground Primary model but is intended to be a generic model. The calculations are performed at a system-wide level to capture the average number of outages per mile and average outage duration by individual non-equipment causes for overhead services. The results of the model in this report should be construed as generic results. As such, there are various parameters that could drive vastly different benefit-to-cost ratios for specific service undergrounding investment, including:

- Number and length of services to be undergrounded
- Difficulty accessing services (e.g., rear-lot, heavy vegetation)
- Associated primary work (e.g., moving from rear-lot front-lot)
- Customer outreach and scheduling
- Count and types of customers
- Age and condition of existing service assets

For this model, multiple investment options are evaluated. Benefits are calculated as the difference in life-cycle cost between the investment option and the Baseline Scenario (i.e., avoided costs). The investment options are summarized below:

- **Baseline Scenario** - Continued operation of this section of the system with a run-to-failure approach
- **Overhead Rebuild** - Rebuilding the services in place with new equipment
- **Overhead to Underground** - Converting the services to underground

Additional details of the model are described in subsequent sections of this report.

3/6/2024

Benefit-to-Cost Analysis Modeling

3.0 Key Assumptions

The BCA models incorporate data input and assumptions analyzed and derived from DTE’s Geographical Information System, Outage Management System, customer / circuit database, and project specific information.

3.1 Geographical Information System

DTE’s GIS provides an asset register of assets across the system. The PTMM model uses the GIS data to determine the count of poles on each circuit, the average age of these poles, and the backbone/lateral status of the pole.

The pole class was used to determine whether the pole is on a backbone or a lateral, as shown in Table 3-1. This categorization is utilized by the PTMM model to determine the customer impact of the pole failure, further detailed in Section 3.3.

Table 3-1 Lateral vs Backbone Pole Classification

Pole Class	Backbone / Lateral
1	Backbone
2	Backbone
3	Backbone
4	Lateral
5	Lateral
6	Lateral

The Overhead to Underground models utilize GIS data and project scoping data to create an asset register for each project, estimating the count and type of each asset that will be placed into service once the project is complete.

3.2 Event Data

The benefit-to-cost analysis models utilize outage event and non-outage event data to model the impact of overhead asset failures across the system. Section 4.4 provides more detail on how the information was used. Additionally, the models use DTE historical data to parse out asset failures that do not result in an outage event (only requiring reactive cost) and asset failures resulting in an outage (requiring reactive cost and causing an outage event). The results of the analysis are shown below in Table 3-2.

Table 3-2 Outage vs Non-Outage Event Assumptions

Event Type	Percent of Asset Failures
Asset failure causing an outage event	45%
Asset failure causing a non-outage event	55%

3/6/2024

Benefit-to-Cost Analysis Modeling

3.3 Customer Data

The BCA models utilize customer counts and types by circuit or by project to quantitatively model the customer impact of outage events. Customers are categorized as residential, small commercial and industrial (Small C&I), and large commercial and industrial (Large C&I) to align with the Department of Energy’s (DOE) Interruption Cost Estimator (ICE) calculator (Refer to Section 4.4.4).

To estimate the customers interrupted (CI) during an average pole-related outage event, data from the OMS was filtered to exclude underground outages and aggregated to calculate the average percent of customers on the circuit that experience an interruption for each protection device type. Backbone events are defined as sustained outages, resulting in a breaker or recloser operating, and lateral events are defined as outages resulting in a fuse operating. The result of this analysis is the average percent of customers on the circuit that experience an interruption for backbone and lateral outage events shown in Table 3-3.

Table 3-3 PTMM Model Customer Impact Assumptions

Backbone/Lateral	Average CI to Circuit Customer Count Ratio
Backbone	45%
Lateral	5%

To further cap the economic impact of lateral pole failures on commercial and industrial customers, the model takes a conservative approach that implements a cap of 5 Small C&I customers and 0 Large C&I customers that a lateral pole failure can impact. Table 3-4 provides the calculations for the average customer impact when a backbone and lateral pole or pole top failure cause an outage on an example circuit, where the circuit has a total of 900 residential customers, 40 small C&I customers, and 5 large C&I customers.

Table 3-4 PTMM Model Outage Customer Impact Example

Customer Category	Formula	Customer Count
Residential Customers impacted by backbone pole failure outage	$900 \times 45\%$	405
Small C&I Customers impacted by backbone pole failure outage	$40 \times 45\%$	18
Large C&I Customers impacted by backbone pole failure outage	$5 \times 45\%$	2.25
Residential Customers impacted by lateral pole failure outage	$900 \times 5\%$	45
Small C&I Customers impacted by lateral pole failure outage	$\text{MIN}(40 \times 5\%, 5)$	2
Large C&I Customers impacted by lateral pole failure outage	$\text{MIN}(5 \times 5\%, 0)$	0

3.4 PTMM Specific Information

Based on DTE’s PTMM experience and an understanding of the current overhead infrastructure condition across the distribution system, the PTMM model estimates additional investments required because of PTMM inspection. Upon inspection, a pole can be categorized as “acceptable,” “restorable reject,” or “non-restorable reject.” These categories and their assumed reject rates are detailed in Table 3-5. No work is required for acceptable poles. Restorable poles are reinforced, which is estimated to extend the pole’s life by 10 years.

3/6/2024

Benefit-to-Cost Analysis Modeling

Non-restorable reject poles are replaced, along with the pole top. Pole tops can be categorized as “Acceptable” or “Defective” following inspection, where defective assets are replaced with pole top assets of the current standard.

Table 3-5 Estimated PTMM Inspection Results

Category	Value
“Acceptable” pole inspection result	90%
“Restorable Reject” pole inspection result	1%
“Non-Restorable Reject” pole inspection result	9%
“Acceptable” pole top equipment inspection result	65%
“Defective” pole top equipment inspection result	35%

It is important to note that the 35% of pole tops with a “Defective” inspection result is in addition to the 9% of non-restorable rejected poles. Therefore, the total percent of poles that receive new pole top assets after inspection totals to 44% (35% + 9%) since pole replacements include pole top replacements.

3/6/2024

Benefit-to-Cost Analysis Modeling

4.0 Benefit-to-Cost Analysis Approach

At its core, the BCA models calculate the benefits of replacing or extending the life of existing infrastructure, leveraging an asset-centric, bottom-up approach. The approach forecasts the probability-weighted consequences for aging infrastructure. The models capture three main categories of cost-based consequences that a given investment option can mitigate: reactive costs, cyclical program costs (e.g., vegetation management), and customer outages, including customer outage costs. The customer outage cost uses the DOE ICE calculator, described in detail in Section 4.4.4 below, to assess the economic impacts to customers during power outages.

The modeling uses asset-level data to perform life-cycle calculations. The models probabilistically project the risk of assets in the future. For each investment option, the models calculate each asset’s life-cycle reactive costs, cyclical program costs, and customer outage costs. The benefit of an investment option is the difference between its life-cycle costs and that of the Baseline Scenario. The following sub-sections describe the approach in further detail.

4.1 Financial Assumptions

Table 4-1 lists key financial assumptions used for the BCA analysis provided by DTE.

Table 4-1 Financial Assumptions

Assumption Name	Unit	Values
Study Length	Years	40
Study Start Year	Year	2024
Discount Rate	%	6.92%
Inflation Rate	%	2.00%

4.2 Upfront Investments

4.2.1 Pole and Pole Top Maintenance and Modernization

Key unit cost and inspection cycle assumptions can be found in Table 4-2 and Table 4-3. It is important to note that the PTMM model is constructed to analyze a single cycle of PTMM to calculate the benefit-to-cost ratio. For the PTMM program, a circuit’s immediate cycle contains the information needed to drive the investment decision at hand. In contrast, the PTMM program in the Overhead to Underground models reflect the present value of cyclical expenditures over the study period as such calculation is more comparable to the investment for the undergrounding option, which avoids many of the future cyclical expenditures.

3/6/2024

Benefit-to-Cost Analysis Modeling

Table 4-2 Unit Cost Assumptions

Activity	Unit of Measure	Value
Pole Visual Inspection	\$ / pole	\$20
Pole Physical Inspection	\$ / pole	\$80
Pole Reinforcement Cost	\$ / pole	\$1,100
Pole Inspection-Based Replacement Cost	\$ / pole	\$11,500
Pole Top Visual Inspection Cost	\$ / pole top	\$20
Pole Top Inspection-Based Replacement Cost	\$ / pole top	\$5,000

Table 4-3 Inspection Cycle Assumptions

Assumption	Years	Notes
Pole Physical Inspection Offset	20	Timeframe between pole installation and first physical inspection.
Pole Visual Inspection Offset	10	Timeframe between pole installation and first visual inspection.
Pole Inspection Cycle	10	Timeframe between pole inspections.
Pole Top Inspection Offset	5	Timeframe between pole top installation and first inspection
Pole Top Inspection Cycle	5	Timeframe between pole top inspections

4.2.2 Overhead Rebuild and Overhead to Underground Conversion Costs

The Appoline and Buffalo Charles pilots have quite different scopes. The Appoline pilot includes 61 residential customers on two city blocks in Detroit. The scope of this project includes installation of approximately 1,300 feet of primary conductor, six transformers, and 61 underground services to residences. The Buffalo-Charles project included 459 customers using front-lot construction. This project will install 3.9 miles of underground primary cable, 4.5 miles of underground secondary cable, 459 underground services to residences, and 48 pad mounted transformers. Furthermore, this project will remove 2.8 miles of overhead primary, 3.5 miles of overhead secondary, and 459 overhead services.

The overhead rebuild and the underground conversion costs for both Appoline and Buffalo Charles are listed in Table 4-4. It is important to note that the overhead rebuild costs are preliminary engineering cost estimates, whereas the overhead to underground conversion costs are either as-built (e.g., Appoline) or as-designed (e.g., Buffalo Charles).

Table 4-4 Pilot Cost Assumptions

Assumption Name	Appoline	Buffalo Charles
Overhead Rebuild	\$246,000	\$2,800,000
Overhead Conversion to Underground	\$895,000	\$17,400,000

3/6/2024

Benefit-to-Cost Analysis Modeling

4.3 Failure Probability Assumptions

The models use failure probability forecasts to assess the value of proactively addressing assets today versus deferring the investment option. In the absence of detailed historical asset failure data, Weibull survivor curves (probability of an asset surviving over time) are used to drive failure probability of an asset.

The models utilize Weibull distribution curves to represent the survivor curves for different asset types. These curves, aligned to DTE’s asset populations, are shown in Figure 4-1, with the parameters listed in Table 4-5.

Table 4-5 Weibull Parameters for Asset Classes Modeled

Asset Class	Alpha	Beta
Pole	4.4	65
Pole Top	3.2	50
Overhead Conductor	4.4	65
Pole Top Transformer	3.2	45
Underground Residential Distribution	3.2	56
Pad Mount Transformer	3.2	45

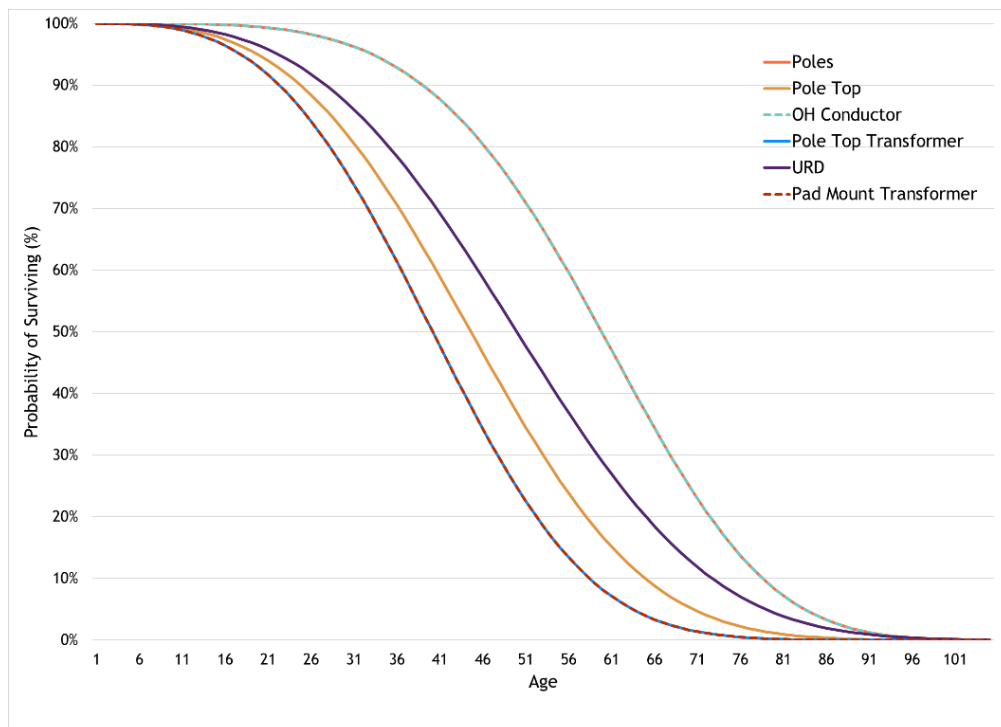

Figure 4-1 DTE’s Asset Weibull Curves

3/6/2024

Benefit-to-Cost Analysis Modeling

The survivor curves are leveraged to forecast an asset’s annual probability of failure given the asset’s age. Using the wood pole asset as an example, Figure 4-2 shows the approach to calculate the annual probability for a 40-year-old wood pole asset to fail between age 40 and age 41 (i.e., 1.35%) and fail between age 41 and age 42 (i.e., 1.44%). This calculation produces a probability density function where the total probability of failure over time is 100 percent, indicating the asset at the given age (i.e., survived till this age) will nonetheless fail in the future but at different probabilities over time.

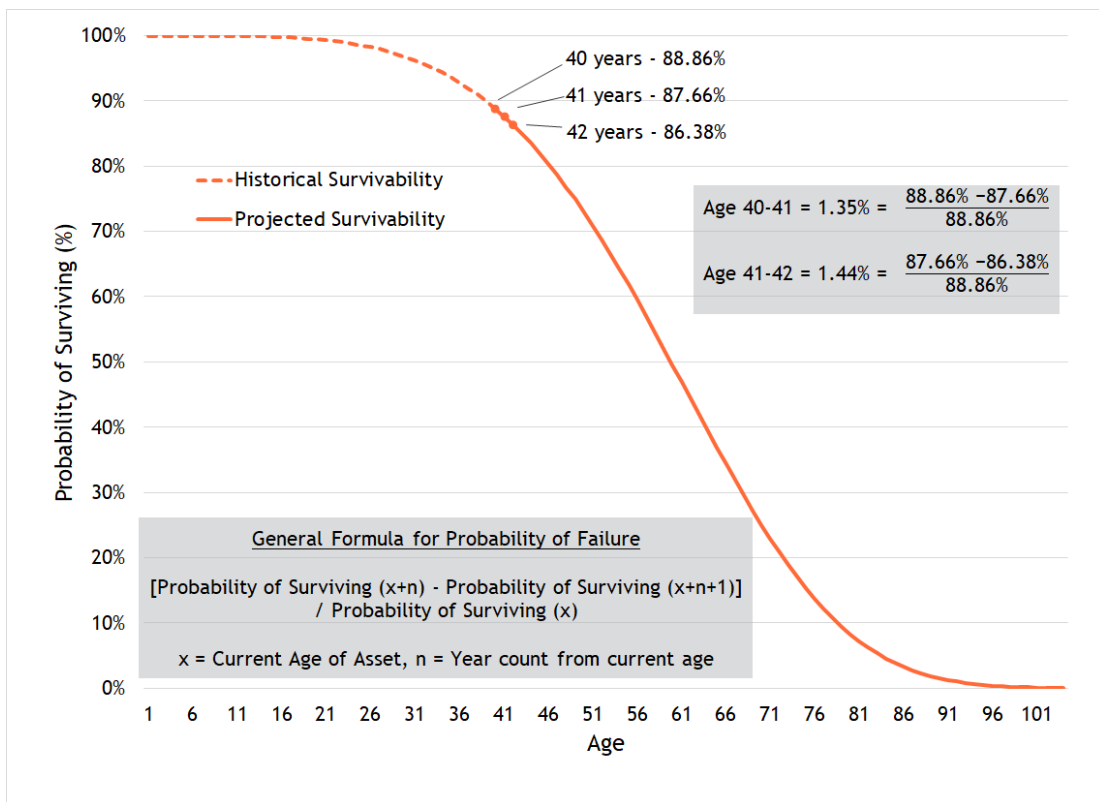

Figure 4-2 Annual Probability of Failure Example: 40-Year-Old Wood Pole

3/6/2024

Benefit-to-Cost Analysis Modeling

Figure 4-3 shows the annual probability of failure, or the probability density functions, for a range of wood pole ages based on the mathematical approach shown in Figure 4-2. The figure shows that as assets get older, their 100% total failure probabilities are distributed over fewer years. Notably, the dotted black curve, by mathematical formulas, illustrates the accelerating increase in an asset’s ‘next year’ probability of failure as it moves further along its survivor curve (See “Pole” survivor curve in Figure 4-1).

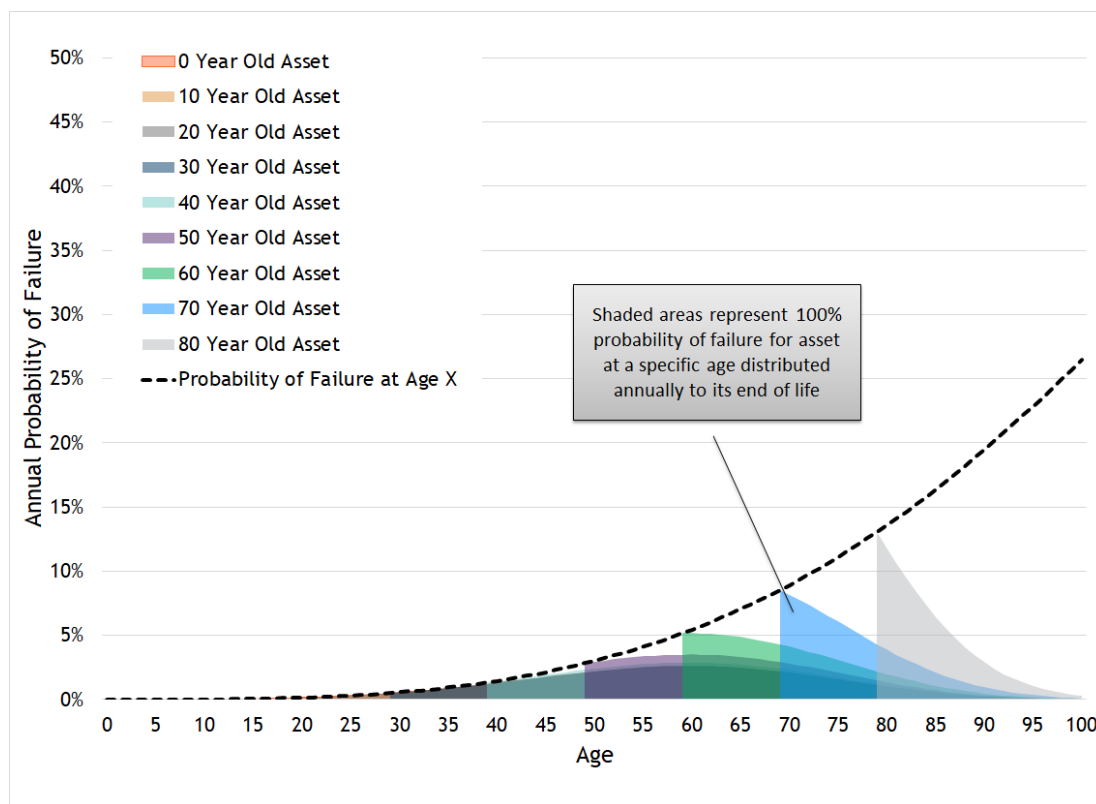

Figure 4-3 Annual Probability of Failure Profiles for Wood Poles

4.4 Avoided Life-cycle Costs (Benefits)

The models include a range of life-cycle costs that affect the Baseline Scenario and the investment options. These include cyclical program costs (e.g., vegetation management) and reactive costs (e.g., equipment failures). When an investment option has a lower life-cycle cost than the Baseline Scenario, that value is an avoided cost, which the model quantifies as a benefit. For example, the Overhead Rebuild investment option has a lower life-cycle equipment failure reactive cost than the Baseline Scenario because it has brand new assets.

Further explanation regarding the types of life-cycle costs and assumptions in the models can be found in the following subsections.

3/6/2024

Benefit-to-Cost Analysis Modeling

4.4.1 Equipment Failure Reactive Costs

When assets fail before being proactively replaced, it creates an urgency to minimize the impact on the customer.

It is common for the cost of replacement or repair during outage restoration to be considerably higher than that when addressed proactively in a planned project.

These costs are captured under the category of asset reactive costs. The increase in reactive cost over the proactive project cost is primarily due to additional effort to restore power before replacing or repair, a loss in capital efficiencies, overtime, and premiums paid to contractor crews and crews from other utilities during larger storms, etc. Table 4-6 provides the estimates for the reactive costs utilized in the models.

Table 4-6 Equipment Failure Reactive Cost Assumptions

Asset Type	Failure Type	Cost [\$]
Pole	Event Based Failure	\$15,000
Pole Top	Event Based Failure	\$8,500
Overhead Transformer	Event Based Failure	\$7,000
Overhead Wire	Event Based Failure	\$8,500
Overhead Service	Event Based Failure	\$3,500
Underground Residential Distribution	Event Based Failure	\$13,000
Transformer UG	Event Based Failure	\$13,000

4.4.2 Non-Equipment Outage Reactive Cost

In addition to asset failures causing outages, there are other causes for customer outages. The model uses the historical OMS data to estimate outages caused by Animals, Tree/Wind, Weather (lightning and ice), and other causes.

The Overhead to Underground Primary model calculates the number of outages per mile and outage duration by individual non-equipment causes based on the historical outages experienced on both the Appoline and Buffalo Charles circuits.

The Overhead to Underground Services model is intended to be a generic model and the calculations are performed at a system-wide level to capture the average number of outages per mile and average outage duration by individual non-equipment causes for overhead services.

When a non-equipment outage occurs, the model estimates two types of costs, the reactive cost (e.g., cost of truck rolls), and the customer outage cost informed by the DOE ICE calculator. Two different reactive cost assumptions are used, a lower truck roll cost for Animal, Weather and other outage causes, and a higher truck roll cost used for the Tree/Wind outages, due to additional tree trimming work involved during customer restoration. The non-equipment outage reactive cost assumptions are shown in **Error! Reference source not found.**

Table 4-7 Non-Equipment Outage Reactive Cost

Assumption	Cost per Outage
Non-Equipment, Non-Tree/Wind Outage Reactive Cost	\$2,000
Tree/Wind Outage Reactive Cost	\$10,000

3/6/2024

Benefit-to-Cost Analysis Modeling

4.4.3 Non-Outage Trouble Reactive Costs

DTE experiences a substantial number of events that require truck rolls, but do not cause customer outages. These events are driven by a multitude of reasons, such as customers calling about sagging service lines, falling tree branches touching electric assets, or follow-up jobs to replace a leaning pole, etc. Six years of historical data from 2018-2023 were analyzed to estimate the counts of events per mile and project the future events that could be reduced to some degree, depending on the investment options. Each investment option is given a reduction factor based on the improvements DTE expects to see after investing, resulting in reduced truck rolls and non-outage reactive costs. In addition, the model incorporates annual degradation factors for the non-outage trouble reduction benefit after the in-service date. Both the initial reduction and degradation factors are shown in Table 4-8. All the non-outage trouble reactive events are assumed to have \$2,000 per event.

Table 4-8 Non-Outage Trouble Reactive Event Reduction

Assumption Description	Initial Reduction	Annual Degradation
PTMM Impact	30%	4%
Overhead Rebuild Impact	90%	None
Overhead to Underground Conversion Impact	95%	None

4.4.4 Customer Outage Cost

One of the main consequences of failure across all asset classes is the outage impact on customers. Using the annual probabilities of failure described in Section 4.3 and the percentage of asset failures that cause an outage in Table 3-2, the model estimates the probability of an asset failing and causing an outage. For each asset class, the expected duration of the outage is estimated based on historical OMS records. Based on the expected duration, shown in Table 4-9, and the expected customers impacted for each asset, the model calculates the customer minutes interrupted (CMI) for each asset. This risk-weighted CMI is monetized using the DOE ICE Calculator (see the following subsection) to estimate each asset’s risk-weighted monetized CMI over time.

Table 4-9 Customer Outage Duration Assumptions

Asset Class	Average Outage Duration (Minutes)
Pole	850
Pole Top	600
Pole Top Transformer	500
Overhead Wire	650
Overhead Service	350
Underground Cable	250
Pad Mount Transformer	200
Underground Service	250

3/6/2024

Benefit-to-Cost Analysis Modeling

4.4.4.1 Interruption Cost Estimator Calculator

To monetize the cost of an outage, the models utilize the ICE Calculator. The ICE Calculator is an electric reliability planning tool developed by Freeman, Sullivan & Co. and Lawrence Berkeley National Laboratory. This tool is designed for electric reliability planners at utilities, government organizations, or other entities interested in interruption costs and/or the benefits associated with reliability improvements in the United States. The ICE Calculator was funded by the Office of Electricity Delivery and Energy Reliability at the U.S. DOE.

The developers of the ICE calculator have also noted increased trends in society's use of technology, including increased reliance on data centers and cloud computing, may have led to an increase in interruption costs since the study was conducted.

The values of interruption costs within the calculator are based on customer surveys from 15 research efforts conducted by 10 utility companies, resulting in 34 different data sets totaling over 105,000 observations from 1989 to 2012. More than 44 thousand Medium to Large C&I customers, greater than 27 thousand small C&I customers, and over 34 thousand residential customers participated in the surveys.

The developers of the ICE calculator have also noted increased trends in society's use of technology, including increased reliance on data centers and cloud computing, may have led to an increase in interruption costs since the study was conducted. With most of the surveys being done before these advancements in the last 10 to 15 years, the developers of the ICE Calculator consider the current cost of interruptions to be conservative¹.

Additional funding has been approved to update the surveys to reflect these key changes, especially the value of interruptions in a post-pandemic society. The update is not expected until the latter half of 2024 or later. The BCA evaluation presented in this whitepaper does not attempt to normalize the ICE Calculator for these factors; rather the evaluation utilizes the results directly from the current calculator, escalated to 2024 dollars, while recognizing that the monetized benefits are likely underestimated.

The calculator includes the estimated interruption costs for residential, small C&I, and large C&I customers for a range of durations. Figure 4-4 shows the cost of interruptions for residential Michigan customers and Figure 4-5 shows the cost of commercial and industrial customers in terms of cost per customer per outage.

¹ <https://eta-publications.lbl.gov/sites/default/files/lbml-6941e.pdf>, page 18

3/6/2024

Benefit-to-Cost Analysis Modeling

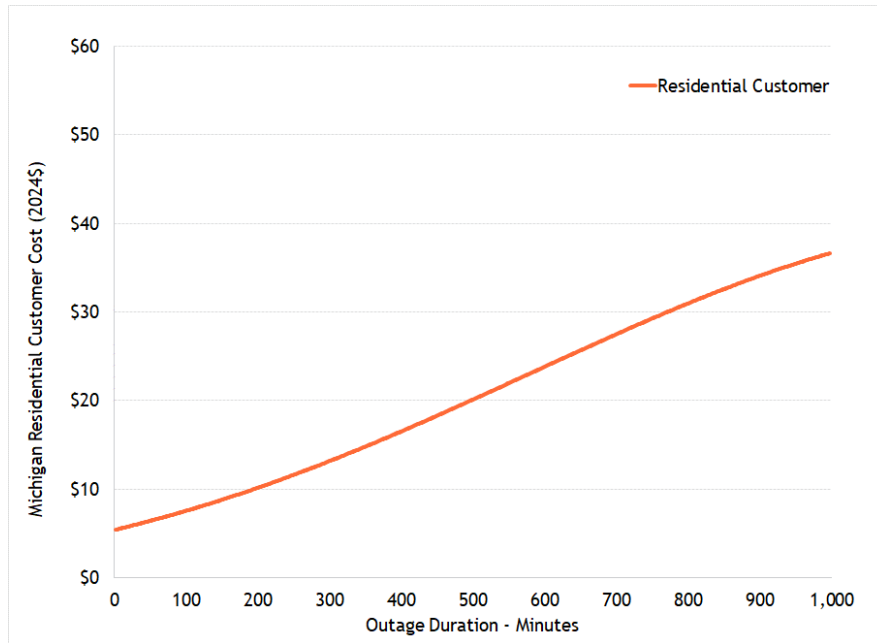

Figure 4-4 Michigan Residential DOE ICE Calculator Values

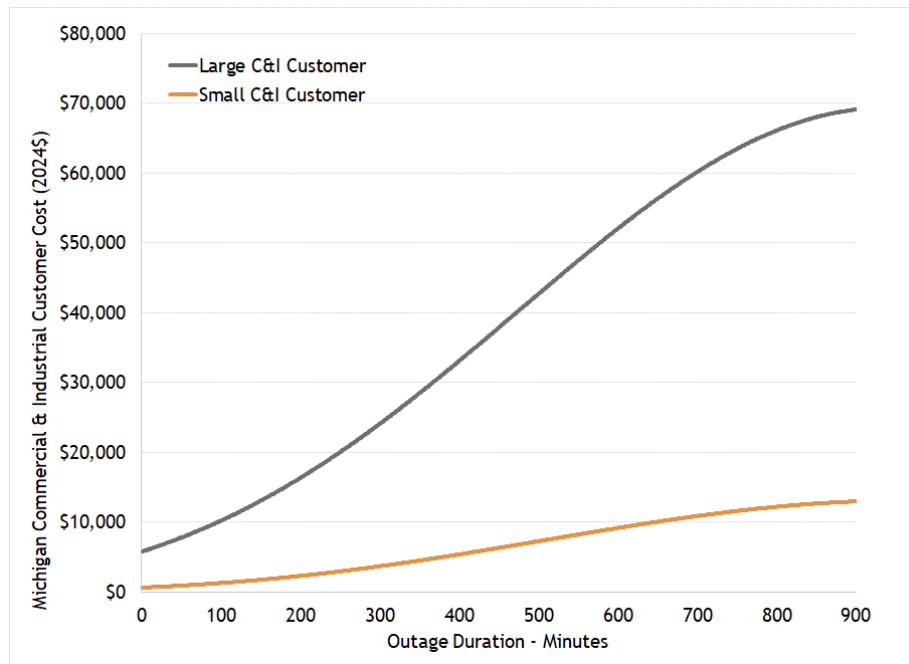

Figure 4-5 Michigan Commercial & Industrial DOE ICE Calculator Values

3/6/2024

Benefit-to-Cost Analysis Modeling

4.4.5 Vegetation Management Costs

Overhead infrastructure commonly requires vegetation management to maintain the right-of-way and minimize tree-related outage events. The model incorporates the costs of performing vegetation management cycles on overhead infrastructure. Vegetation management costs were applied to the Baseline Scenario, PTMM investment option, and Overhead Rebuild investment option. There are no vegetation management costs when the existing overhead infrastructure is converted to underground.

4.4.6 Wire Down Events

Safety was not explicitly quantified in the BCA analysis but is a key driver for many strategic investment decisions for electric distribution utilities.

· · · · ·
· · ·
· · ·

DTE will realize a higher level of safety from reduced wire down risk by upgrading existing overhead infrastructure or converting the existing overhead infrastructure to underground.

· · · · ·
· · · · ·
· · · · ·

Replacing older, weaker assets with stronger, newer, or underground assets decreases the likelihood of failure. Like the non-outage trouble,

each investment option is given a reduction factor based on the improvements DTE expects after the in-service date.

In addition, the model incorporates annual degradation factors for the wire down reduction benefit after the in-service date. The initial improvement and degradation factors are shown in Table 4-10.

Table 4-10 Wire Down Event Reductions

Assumption Description	Initial Reduction	Annual Degradation
PTMM Impact	30%	4%
Overhead Rebuild Impact	90%	None
Overhead to Underground Conversion Impact	100%	None

3/6/2024

Benefit-to-Cost Analysis Modeling

5.0 Model Results

5.1 Pole and Pole Top Maintenance and Modernization Model

The PTMM model calculates a BCR for each circuit. If the circuit's BCR is greater than or equal to 1, then performing PTMM on the circuit produces economic value over its life-cycle that outweighs the circuit PTMM investment.

Figure 5-1 shows a histogram of the benefit-to-cost ratio for the 2,242 circuits modeled. These results indicate a compelling business case for the PTMM program, where 95% (2,124 out of 2,242) of the analyzed circuits have a benefit-to-cost ratio of no less than 1.

The 118 circuits that have BCRs less than 1 have less customers and/or younger poles than the cost-beneficial circuits. On average, these circuits only have about 600 customers, while the cost-beneficial circuits have more than 1,000 customers. On average, these circuits are approximately 10 years younger than the cost-beneficial circuits. Since equipment failures are less frequent for circuits with younger poles, the forecasted risk (i.e., failure probability, customer impacts, etc.) of these circuits is less than that of older circuits.

Given the strong benefit-to-cost ratios, the PTMM program demonstrates a significant value to DTE's customers.

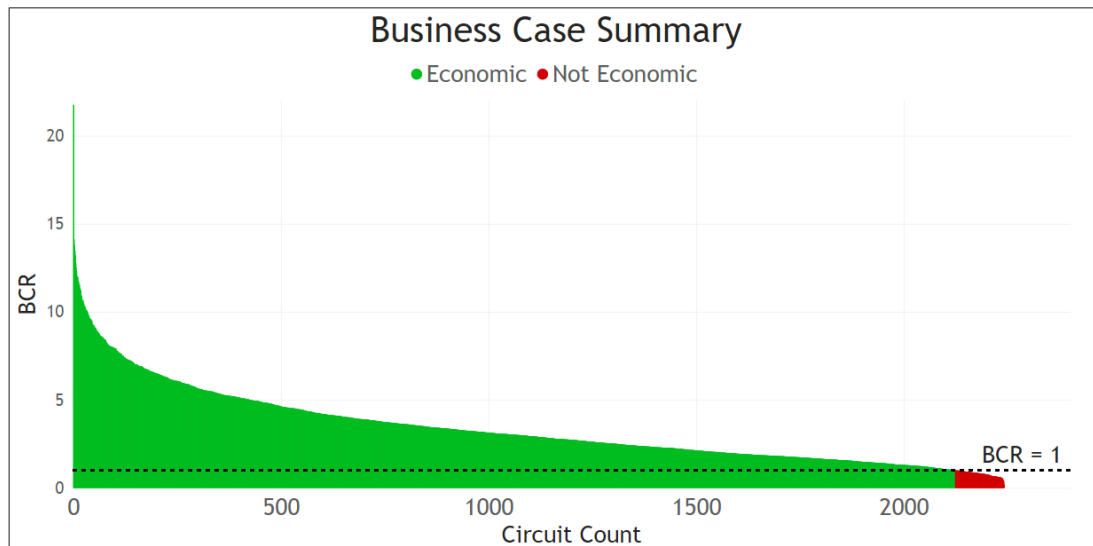

Figure 5-1 PTMM BCA Summary

3/6/2024

Benefit-to-Cost Analysis Modeling

5.2 Overhead to Underground Primary Model

The Overhead to Underground Primary model compares three investment options (PTMM, Overhead Rebuild, and Overhead to Underground Conversion) to the Baseline Scenario. This model is specifically for Appoline and Buffalo Charles. The BCR results allow for the comparison among different investment options.

The results for both project models are shown in Figure 5-2 and Figure 5-3, respectively. For both projects, the Overhead Rebuild investment option has the highest BCR. The BCRs for the PTMM option for both projects are less than 1.0. This is mainly due to relatively low customer density and absence of non-residential customers being served by the assets.

Undergrounding brings a set of unique values when compared to other investment options

The BCRs for undergrounding on both projects are less than 1.0; however the model does not account for unique and less tangible values brought by undergrounding when compared to other investment options, including:

- **Safety:** Undergrounding **eliminates** public and employee safety risk associated with downed wires and structures. Other investment options will only **mitigate** safety risk if the electric infrastructure remains overhead and exposed to elements.
- **Resiliency for catastrophic events:** While this model incorporates major event day historical data, the calculation of the outage duration is based on an average, deterministic approach. It does not specifically model risk and impact of long-duration outages on customers and communities following a catastrophic event.
- **Size of the benefits:** Undergrounding drives the highest reduction in emergent reactive cost, cyclical program cost and customer outages when compared to other investment options.

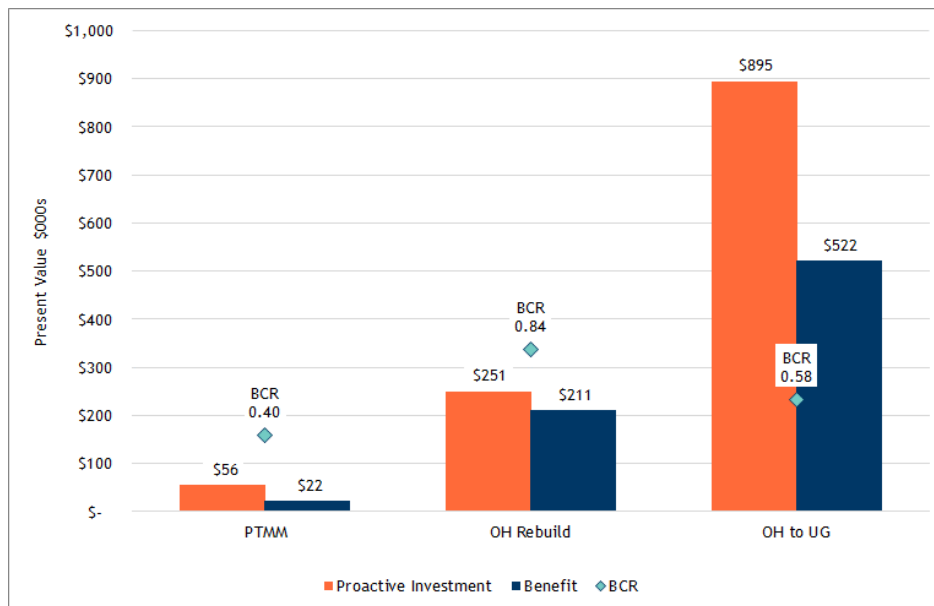

Figure 5-2 Appoline BCA Results

3/6/2024

Benefit-to-Cost Analysis Modeling

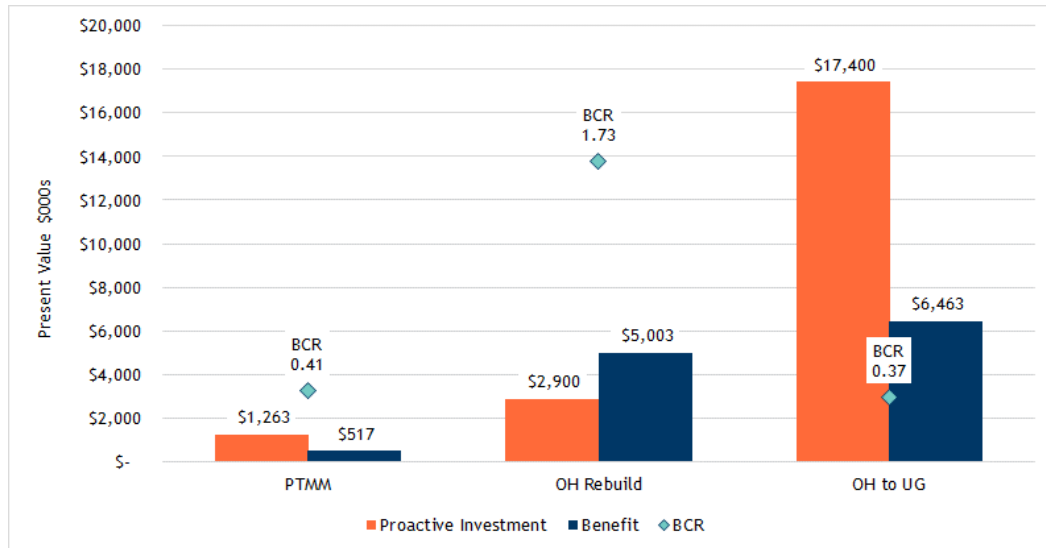

Figure 5-3 Buffalo Charles BCA Results

5.2.1 DTE’s Overhead to Underground Conversion Strategy

As DTE continues to evolve its strategy for converting overhead to underground, there are some considerations when identifying and prioritizing value-producing investments.

Like many utilities across the country that are exploring overhead to underground conversion programs, DTE is also wrestling with the tradeoffs in benefits and costs

Undergrounding single-phase laterals is typically lower cost per mile than undergrounding trunk lines or lines in densely populated areas, but densely populated areas will benefit more customers per mile. Like many utilities across the country that are exploring overhead to underground conversion programs, DTE is also wrestling with the tradeoffs in benefits and costs between doing surgical, targeted undergrounding or large-scale undergrounding (e.g., overhead to underground conversion for entire circuits).

Both Appoline and Buffalo Charles are considered small-scale, neighborhood undergrounding pilots. Through these pilot projects, DTE is gaining valuable insights to mature its engineering, design, and construction process, and refine its methodology to better “target” and “scope” areas for undergrounding. As the program scales up, DTE will be able to realize economies of scale and efficiency gains from design/engineering to construction, reduce the project cost, extract the highest benefits relative to other investment options, and continue to enhance the value proposition of undergrounding in a more targeted manner.

Lastly, the BCA models presented in this whitepaper do not explicitly model catastrophic events, where customers are waiting for multiple days to have power restored. Additional resilience modeling would demonstrate additional benefit, particularly under scenarios where more extreme weather events become more prevalent in future years.

3/6/2024

Benefit-to-Cost Analysis Modeling

Ultimately, the long-term benefit and cost tradeoff for overhead to underground conversion is complex, but DTE is committed to evaluating the various facets to balance these considerations for its customers.

5.3 Overhead to Underground Services Model

The methodology for the Overhead to Underground Services model is similar to the Overhead to Underground Primary model used for Appoline and Buffalo Charles. Figure 5-4 shows the benefit-to-cost results for a generic, 50-year-old overhead service serving one residential customer, under Overhead Rebuild and Overhead to Underground Conversion investment options. As discussed in Section 2.3, the results of the model should be construed as generic results. There are various parameters that could drive vastly different benefit-to-cost ratios for specific service undergrounding investment, including:

- Number and length of services to be undergrounded
- Difficulty accessing services (e.g., rear-lot, heavy vegetation)
- Associated primary work (e.g., moving from rear-lot front-lot)
- Customer outreach and scheduling
- Count and types of customers
- Age and condition of existing service assets

For instance, if the modeled service were for a small C&I customer, the benefit would be greater due to the higher customer outage cost avoided. Additionally, if the infrastructure is older and thus has a higher likelihood of failure, it would be more beneficial to invest in the asset proactively.

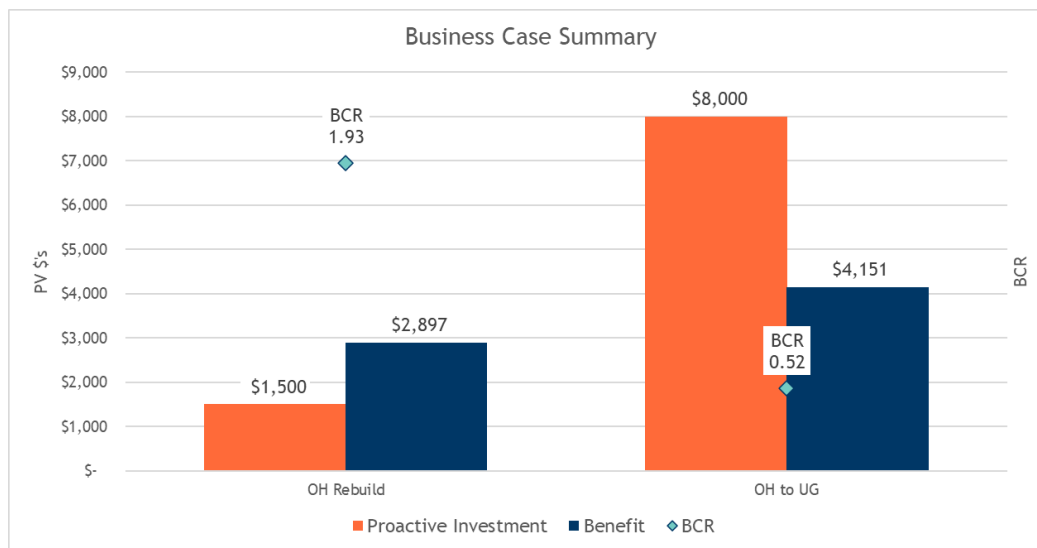
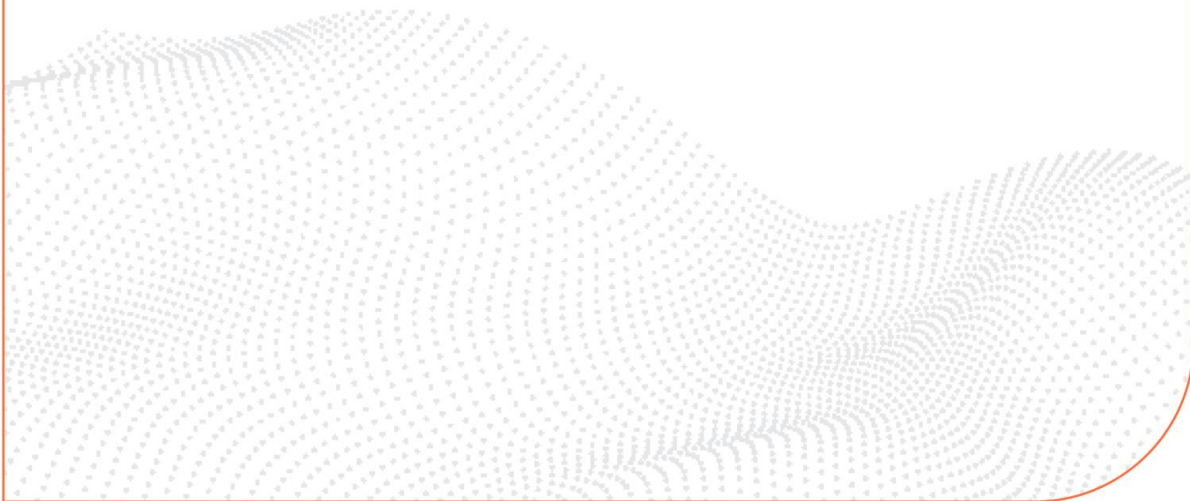

Figure 5-4 Generic Overhead Service Investment Option Results



1898andco.com



Michigan Public Service Commission
DTE Electric Company
GPM Project and Program Rankings

Case No.: U-21534
Exhibit: A-23
Schedule: M14
Witness: A. Krscynski
Page: 1 of 3

(a)	(b)	(c)	(d)	(e)	(f)	(g)	(h)	(i)	(j)	(k)	(l)	(m)	(n)	(o)
GPM Score by Impact Dimension														
GPM Ranking	Description	A12 Tab	A12 Line Number	Reduce		Capacity Relief	Regulatory Compliance	Investment in EJ communities	Major Event Risk	O&M		Capital Avoidance	Total Score	
				Electrical Hazards	Overload Relief					Avoidance	Avoidance			
1	ADMS: DMS/OMS	A-12 B5.4 Tech	3	0	0	0	0	53	233	752	277	7	85	1,407
2	Pole and Pole Top Maintenance and Modernization (PTMM)	A-12 B5.4 Resilience	13	65	0	0	200	53	0	291	353	166	132	1,260
3	Frequent Outage Program (CEMI)	A-12 B5.4 Resilience	15	0	0	0	200	53	0	334	367	97	77	1,128
4	Subtransmission Redesign & Rebuild: Tie 1568	A-12 B5.4 Redesign	16	0	442	448	0	0	108	0	0	0	0	998
5	40 kV: Automatic Pole Top Switch	A-12 B5.4 Resilience	20	0	0	0	0	53	0	356	416	0	48	873
6	4.8 kV CC: Hawthorne Relief and Circuit Conversion	A-12 B5.4 Redesign	47	230	9	8	0	24	19	146	125	191	97	848
7	4.8 kV Hardening	A-12 B5.4 Resilience	12	125	0	0	0	173	0	75	126	146	116	761
8	CODI: Charlotte Network Upgrade	A-12 B5.4 Redesign	28	588	3	2	0	119	20	0	0	0	0	732
9	Distribution Automation	A-12 B5.4 Tech	2	286	0	0	0	53	0	208	138	0	0	685
10	Subtransmission Redesign & Rebuild: Trunk 2237-ST	A-12 B5.4 Redesign	9	0	417	211	0	0	0	0	0	0	0	628
11	CODI: Garfield Network Upgrade	A-12 B5.4 Redesign	81	367	4	1	0	179	24	4	4	9	3	596
12	Subtransmission Redesign & Rebuild: Trunk 7105	Planned for IRM		0	302	130	0	122	0	0	0	0	0	554
13	Substation Risk: Savage	A-12 B5.4 Resilience	5	0	0	0	0	0	532	0	0	0	0	532
14	Subtransmission Redesign & Rebuild: Trunk 7106	A-12 B5.4 Redesign	7	0	300	197	0	0	0	0	0	0	0	497
15	4.8 kV CC: ISO Conversion Program	A-12 B5.4 Redesign	87	130	0	0	0	81	0	70	0	100	80	461
16	4.8 kV CC: Zenon Circuit Conversion Phase 2	A-12 B5.4 Redesign	83	71	0	1	0	195	0	30	36	59	25	417
17	Subtransmission Redesign & Rebuild: Trunk 2419	Planned for IRM		0	196	50	0	165	0	0	0	0	0	410
18	CODI: Howard Conversion	A-12 B5.4 Redesign	36	213	3	1	0	174	3	0	2	2	1	401
19	4.8 kV CC: McKinstry Sub Decommission	A-12 B5.4 Redesign	43	0	0	0	0	0	0	0	0	372	0	372
20	Substation Risk: Port Huron	A-12 B5.4 Resilience	7	0	0	0	0	0	351	0	0	0	0	351
21	8.3 kV CC: Pontiac Overhead/Underground Conversion	A-12 B5.4 Redesign	90	20	0	1	0	200	19	24	34	27	16	340
22	4.8 kV CC: Grosse Pointe Substation and Circuit Conversion	Planned for IRM		78	1	1	0	77	20	41	30	60	31	340
23	Subtransmission Redesign & Rebuild: Trunk 2255	A-12 B5.4 Redesign	8	0	188	95	0	0	46	0	0	0	0	329
24	4.8kV CC: Barber Substation and Circuit Conversion	Planned for IRM		65	15	14	0	131	0	21	25	29	21	320
25	Subtransmission Redesign & Rebuild - Trunk 2448	Planned for IRM		0	102	26	0	189	0	0	0	0	0	317
26	CODI: Targeted Network Secondary Cable Replacement	A-12 B5.4 Redesign	29	309	0	0	0	0	0	0	0	0	0	309
27	4.8 kV CC: I-94 Substation and Circuit Conversion (Promenade)	A-12 B5.4 Redesign	39	40	1	1	0	192	2	17	12	27	14	305
28	Substation Risk: Chestnut	A-12 B5.4 Resilience	4	0	0	0	0	139	156	0	0	0	0	295
29	Cable Replacement Program	A-12 B5.4 Resilience	14	0	0	0	0	53	190	5	0	0	39	287
30	Subtransmission Redesign & Rebuild: Trunk 1444	Planned for IRM		0	280	0	0	0	0	0	0	0	0	280
31	CODI: Islandview Substation	A-12 B5.4 Redesign	31	28	3	1	0	196	12	6	7	16	7	277
32	Subtransmission Redesign & Rebuild: Tie 3416 Reconductoring	Planned for IRM		0	160	62	0	0	15	0	0	34	0	271
33	Subtransmission Redesign & Rebuild: Bernard	Planned for IRM		0	0	265	0	0	0	0	0	0	0	265
34	CODI: Kent/Gibson Conversion	A-12 B5.4 Redesign	82	14	0	1	0	187	8	9	10	14	6	248
35	Subtransmission Redesign & Rebuild: Trunk 7386	Planned for IRM		0	148	60	0	36	0	0	0	0	0	244
36	URD Replacement Program	A-12 B5.4 Resilience	18	0	0	0	0	53	0	50	0	15	122	240
37	Subtransmission Redesign & Rebuild: Trunk 7333	A-12 B5.4 Redesign	10	0	170	69	0	0	0	0	0	0	0	239
38	CODI: Alfred Substation Expansion	A-12 B5.4 Redesign	35	0	28	11	0	200	0	0	0	0	0	238
39	Subtransmission Redesign & Rebuild: Trunk 4217	A-12 B5.4 Redesign	17	0	111	22	0	47	54	0	0	0	0	235
40	4.8 kV CC: Birmingham Decommissioning and Circuit Conversion	A-12 B5.4 Redesign	86	44	1	3	0	0	75	26	24	43	15	233
41	Subtransmission Redesign & Rebuild: Trunk 2455	Planned for IRM		0	0	33	0	175	21	0	0	0	0	229
42	Subtransmission Redesign & Rebuild: Hurst	Planned for IRM		0	53	173	0	0	0	0	0	0	0	226
43	4.8 kV CC: Cortland / Oakman / Linwood Consolidation	A-12 B5.4 Redesign	37	0	17	13	0	190	0	0	0	0	0	219
44	Subtransmission Redesign & Rebuild: Tie 6907	Planned for IRM		0	0	216	0	0	0	0	0	0	0	216
45	Subtransmission Redesign & Rebuild: Cortland Station Expansion	A-12 B5.4 Redesign	78	0	0	0	0	191	20	0	0	0	0	212
46	Breaker Replacement Program	A-12 B5.4 Resilience	16	0	0	0	0	53	19	29	0	27	80	207
47	Substation Risk: McGraw	A-12 B5.4 Resilience	9	0	0	0	0	194	9	0	0	0	0	203
48	4.8 kV CC: Belleville Substation and Circuit Conversion	Planned for IRM		26	0	14	0	0	27	37	46	32	14	197
49	Subtransmission Redesign & Rebuild: Sandusky Transformer 101 Breaker	A-12 B5.4 Redesign	11	0	196	0	0	0	0	0	0	0	0	196
50	Subtransmission Redesign & Rebuild: Waterman	Planned for IRM		0	0	0	0	185	0	0	0	0	0	185

Michigan Public Service Commission
DTE Electric Company
GPM Project and Program Rankings

Case No.: U-21534
Exhibit: A-23
Schedule: M14
Witness: A. Krzyscynski
Page: 2 of 3

(a)	(b)	(c)	(d)	(e)	(f)	(g)	(h)	(i)	(j)	(k)	(l)	(m)	(n)	(o)
GPM Score by Impact Dimension														
GPM Ranking	Description	A12 Tab	A12 Line Number	Reduce		Capacity Relief	Regulatory Compliance	Investment in EJ communities	Major Event Risk	O&M		Capital Avoidance	Total Score	
				Electrical Hazards	Overload Relief					Avoidance	Avoidance			
51	4.8 kV CC: Buckler Circuit Conversion	A-12 B5.4 Redesign	42	52	0	0	0	0	0	18	29	53	24	176
52	4.8 kV CC: MAUME 8241 Downtown Clawson Conversion	A-12 B5.4 Redesign	49	0	0	0	0	0	0	65	0	73	34	172
53	Subtransmission Redesign & Rebuild: Trunk 3546	Planned for IRM	0	0	97	49	0	0	24	0	0	0	0	170
54	Subtransmission Redesign & Rebuild: Trunk 3509	A-12 B5.4 Redesign	18	0	105	27	0	25	13	0	0	0	0	169
55	Subtransmission Redesign & Rebuild: Oak Beach Capacitor	A-12 B5.4 Redesign	25	0	163	0	0	0	0	0	0	0	0	163
56	4.8kV CC: Yale-Slater Decommissioning and Circuit Conversion	Planned for IRM	0	24	8	5	0	0	0	27	23	44	14	144
57	Substation Risk: Savage Switchgear Replacement	A-12 B5.4 Resilience	34	0	0	0	0	0	139	0	0	0	0	139
58	4.8 kV CC: Royal Oak Substation and Circuit Conversion	Planned for IRM	0	27	0	0	0	22	4	27	18	20	10	129
59	Station Upgrade: Navarre	A-12 B5.4 Resilience	32	0	0	0	0	128	0	0	0	0	0	128
60	Substation Risk: Apache	A-12 B5.4 Resilience	6	0	0	0	0	0	126	0	0	0	0	126
61	Station Upgrade: Warren (Relay Replacement)	A-12 B5.4 Resilience	23	0	0	0	0	0	0	0	0	126	0	126
62	Subtransmission Redesign & Rebuild: Boyne	A-12 B5.4 Redesign	12	3	28	30	0	34	0	7	13	7	3	126
63	4.8kV CC: Hemlock Decommissioning and Circuit Conversion	A-12 B5.4 Redesign	88	32	0	1	0	0	0	29	25	25	12	124
64	4.8 kV CC: Hilton Substation and Circuit Conversion	A-12 B5.4 Redesign	54	28	0	0	0	31	14	0	12	23	11	120
65	Subtransmission Redesign & Rebuild: Trunk 2308	A-12 B5.4 Redesign	70	0	0	14	0	53	0	6	16	17	6	112
66	Substation Risk: Belleville Switchgear Decommission	A-12 B5.4 Resilience	8	0	0	0	0	0	109	0	0	0	0	109
67	Subtransmission Redesign & Rebuild: 40kV Capacitor Banks at Armada and Adair	A-12 B5.4 Redesign	24	0	30	79	0	0	0	0	0	0	0	108
68	4.8kV CC: Rochester Decommissioning and Tienken Relief	Planned for IRM	0	25	3	2	0	0	6	26	11	16	8	97
69	System Loading: Jewell	A-12 B5.4 Redesign	100	8	8	12	0	0	26	17	13	9	4	95
70	Subtransmission Redesign & Rebuild: Tie 3705	Planned for IRM	0	0	94	0	0	0	0	0	0	0	0	94
71	4.8kV CC: SCOTN	A-12 B5.4 Redesign	52	0	0	0	0	0	0	0	0	91	0	91
72	4.8 kV CC: Calla Circuit Conversion and Phase 2	A-12 B5.4 Redesign	84	0	0	21	0	0	0	11	15	36	6	89
73	Subtransmission Redesign & Rebuild: Tie 6602	Planned for IRM	0	1	0	27	0	0	0	6	8	40	3	84
74	Substation Risk: Seville	A-12 B5.4 Resilience	35	0	0	4	0	0	79	0	0	0	0	83
75	Subtransmission Redesign & Rebuild: Trunk 4245	A-12 B5.4 Redesign	75	0	0	54	0	22	6	0	0	0	0	82
76	Subtransmission Redesign & Rebuild: Trunk 4266	A-12 B5.4 Redesign	19	0	0	18	0	2	61	0	0	0	0	81
77	System Loading: Macomb/Golf	A-12 B5.4 Redesign	97	2	15	25	0	0	0	7	18	5	3	75
78	CODI: Corktown Substation	A-12 B5.4 Redesign	30	0	0	12	0	0	63	0	0	0	0	75
79	Subtransmission Redesign & Rebuild: Badax Transformer 102 Addition	A-12 B5.4 Redesign	74	0	0	17	0	0	0	0	0	0	0	73
80	Station Upgrade: Northeast (Relay Replacement)	A-12 B5.4 Resilience	24	0	0	0	0	0	0	0	0	72	0	72
81	Substation Risk: Hood	A-12 B5.4 Resilience	26	0	0	0	0	70	0	0	0	0	0	70
82	System Loading: Globe	A-12 B5.4 Redesign	63	0	0	63	0	0	0	0	0	3	2	68
83	System Loading: Richmond/Armada	A-12 B5.4 Redesign	94	1	4	5	0	0	37	4	5	8	2	66
84	Subtransmission Redesign & Rebuild: Derby	Planned for IRM	0	0	23	41	0	0	0	0	0	0	0	64
85	Subtransmission Redesign & Rebuild: Trunk 4911	A-12 B5.4 Redesign	76	0	38	12	0	0	0	0	0	13	0	63
86	System Loading: Diamond	A-12 B5.4 Redesign	104	0	0	61	0	0	0	0	0	0	0	61
87	System Loading: Kings Point	A-12 B5.4 Redesign	110	5	12	14	0	15	0	4	4	3	2	60
88	Subtransmission Redesign & Rebuild: Custer Republic	A-12 B5.4 Redesign	77	0	0	0	0	60	0	0	0	0	0	60
89	Subtransmission Redesign & Rebuild: Thumb Electric Fault Isolation	Planned for IRM	0	0	0	0	0	0	0	0	0	0	58	58
90	System Loading: Port Sanilac	A-12 B5.4 Redesign	93	9	2	1	0	0	0	19	18	6	3	58
91	System Loading: Carleton	A-12 B5.4 Redesign	58	0	48	10	0	0	0	0	0	0	0	57
92	Subtransmission Breaker Short Circuit Violations	A-12 B5.4 Redesign	22	0	0	0	0	53	0	0	0	0	0	53
93	4.8 kV CC: Unionville DC 301 B1 Conversion	A-12 B5.4 Redesign	56	12	0	0	0	0	0	6	11	17	6	52
94	4.8kV CC: Pittsfield Substation and Circuit Conversion	Planned for IRM	0	21	0	1	0	0	0	0	0	21	8	50
95	4.8 kV CC: Almont Relief and Circuit Conversion (Midas)	A-12 B5.4 Redesign	41	2	0	6	0	0	28	5	3	4	1	50
96	System Loading: Grenada	A-12 B5.4 Redesign	98	4	0	2	0	0	0	11	8	19	3	48
97	System Loading: New Baltimore/Chesterfield	A-12 B5.4 Redesign	109	11	6	10	0	0	0	3	3	8	4	45
98	System Loading: Tahoe	A-12 B5.4 Redesign	108	0	0	43	0	0	0	0	0	0	0	43
99	System Loading: Lark/Spruce	A-12 B5.4 Redesign	99	2	0	9	0	0	0	6	6	16	3	42
100	4.8 kV CC: Unionville Decommissioning and Circuit Conversion	Planned for IRM	0	3	19	5	0	0	0	2	3	6	2	41

Michigan Public Service Commission
DTE Electric Company
GPM Project and Program Rankings

Case No.: U-21534
Exhibit: A-23
Schedule: M14
Witness: A. Krzyscynski
Page: 3 of 3

(a)	(b)	(c)	(d)	(e)	(f)	(g)	(h)	(i)	(j)	(k)	(l)	(m)	(n)	(o)		
GPM Score by Impact Dimension																
GPM Ranking	Description	A12 Tab	A12 Line Number	Reduce		Capacity Relief	Regulatory Compliance	Investment in EJ communities	Major Event Risk	SAIDI		SAIFI		O&M Avoidance	Capital Avoidance	Total Score
				Electrical Hazards	Overload Relief					SAIDI	SAIFI					
101	Substation Risk: Imlay	A-12 B5.4 Resilience	36	13	0	3	0	0	0	0	0	0	17	6	39	
102	System Loading: Disco	A-12 B5.4 Redesign	107	0	16	24	0	0	0	0	0	0	0	0	39	
103	System Loading: Wixom	A-12 B5.4 Redesign	103	0	2	6	0	0	20	3	3	2	1	38		
104	Subtransmission Redesign & Rebuild: Tie 7504	A-12 B5.4 Redesign	67	3	5	10	0	0	0	2	3	14	1	38		
105	Subtransmission Redesign & Rebuild: Tie 810	A-12 B5.4 Redesign	66	2	2	6	0	0	0	4	5	14	2	35		
106	Subtransmission Redesign & Rebuild: Tie 4105	A-12 B5.4 Redesign	13	2	0	0	0	0	0	6	10	16	1	34		
107	Subtransmission Redesign & Rebuild: Slocum	A-12 B5.4 Redesign	23	0	0	0	0	0	0	0	0	33	0	33		
108	Subtransmission Redesign & Rebuild: Tie 5208	Planned for IRM		0	26	7	0	0	0	0	0	0	0	0	33	
109	System Loading: Goodison	A-12 B5.4 Redesign	102	0	9	16	0	0	0	2	2	2	1	32		
110	4.8 kV CC: GRFIN & WMSTN Conversions	A-12 B5.4 Redesign	51	0	0	1	0	0	0	0	0	27	3	31		
111	4.8 kV CC: White Lake Decommissioning and Circuit Conversion	A-12 B5.4 Redesign	89	4	7	4	0	0	0	4	4	6	2	31		
112	Station Upgrade: Lincoln	A-12 B5.4 Resilience	29	0	0	0	0	30	0	0	0	0	0	30		
113	Subtransmission Redesign & Rebuild: Tie 4104	A-12 B5.4 Redesign	73	2	0	0	0	0	0	4	4	17	1	29		
114	4.8 kV CC: Pinegrove Substation Relocation and Conversion	A-12 B5.4 Redesign	45	8	0	0	0	0	0	7	5	4	3	27		
115	System Loading: Sterling	A-12 B5.4 Redesign	106	0	0	7	0	0	0	4	8	5	3	27		
116	CODI: Midtown Substation Expansion	A-12 B5.4 Redesign	34	0	6	21	0	0	0	0	0	0	0	27		
117	System Loading: Mayville	A-12 B5.4 Redesign	101	1	10	7	0	0	0	1	1	2	1	23		
118	4.8 kV CC: Lapeer - Elba Expansion and Circuit Conversion (Apollo)	A-12 B5.4 Redesign	85	2	5	4	0	0	0	3	3	4	1	23		
119	Subtransmission Redesign & Rebuild: Trunk 4601	Planned for IRM		0	6	16	0	0	0	0	0	0	0	23		
120	System Loading: Otsego/Capac/Shaw	A-12 B5.4 Redesign	96	0	2	2	0	0	0	3	5	9	2	22		
121	System Loading: Brown City	A-12 B5.4 Redesign	92	2	8	5	0	0	0	0	2	3	1	21		
122	CODI: CATO Substation Expansion	A-12 B5.4 Redesign	79	0	13	7	0	0	0	0	0	0	0	21		
123	Subtransmission Redesign & Rebuild: Pigeon Area Improvement	Planned for IRM		0	4	6	0	0	0	0	0	9	0	19		
124	System Loading: Cody	A-12 B5.4 Redesign	95	0	6	7	0	0	0	1	2	2	1	19		
125	Subtransmission Redesign & Rebuild: Tie 3205	A-12 B5.4 Redesign	71	2	0	0	0	0	0	0	0	13	0	16		
126	Subtransmission Redesign & Rebuild: STPS6	Planned for IRM		0	0	0	0	0	0	0	0	13	0	13		
127	4.8 kV CC: Quincy Conversion	A-12 B5.4 Redesign	44	2	0	0	0	0	0	2	1	5	1	10		
128	System Loading: Spokane/Seneca	A-12 B5.4 Redesign	105	0	0	10	0	0	0	0	0	0	0	10		
129	Ann Arbor System Improvements	A-12 B5.4 Redesign	2	0	0	1	0	0	1	0	0	1	0	2		