

STATE OF MICHIGAN
BEFORE THE MICHIGAN PUBLIC SERVICE COMMISSION

* * * * *

In the matter of the application of)	
MEI Telecom, Inc.)	
for designation as an eligible)	Case No. U-20952
telecommunications Lifeline carrier)	
in the State of Michigan.)	
_____)	

**AMENDED APPLICATION OF MEI TELECOM, INC FOR DESIGNATION AS AN ELIGIBLE
TELECOMMUNICATIONS CARRIER IN THE STATE OF MICHIGAN**

I. INTRODUCTION

MEI Telecom, Inc. (“MEI”) pursuant to Section 214(e)(2) of the Communications Act of 1934, as amended (the “Act”), Sections 54.01 through 52.207 of the Rules of the Federal Communications Commission (“FCC”), and the Rules and Regulations of the Michigan Public Service Commission (“Commission”), hereby submits this amended Application for Designation as an Eligible Telecommunications Carrier (“ETC”) in the State of Michigan. MEI seeks ETC designation to receive support from the Federal Universal Service Fund (“USF”), including funds under the FCC’s Rural Digital Opportunity Fund. MEI seeks to be designated as both a High-Cost Eligible Telecommunications Carrier and a Lifeline Eligible Telecommunications Carrier. As provided herein, MEI meets all the statutory and regulatory requirements for designation as an ETC in Michigan. Such a designation advances the public interest because it will enable MEI to provide Lifeline services to low-income Michigan residents and receive federal funding to build

critical telecommunications infrastructure in Michigan. For these reasons, MEI respectfully requests that the Commission approve this Application for ETC designation.

The contact information for MEI is:

David Stoll
MEI Telecom, Inc.
123 W. Orchard
Delton, MI 49046
269-623-9971
execadmin@mei.net

All correspondence, pleadings, notices, orders, and decisions concerning this application should be directed to MEI's counsel:

Brian McDermott
Strategies Law Group, PLLC
1002 Parker Street
Falls, Church, VA 22046
bmcdermott@stratlg.com
571-730-4970

II. DESCRIPTION OF THE APPLICANT

MEI Telecom, Inc. was founded in 2013 and is incorporated under the laws of the State of Michigan. MEI has a permanent license to provide basic local exchange services in Michigan pursuant to Case No. U-17431. MEI currently provides data services to approximately 800 subscribers through its wireless network, as well as communications services to 214 voice and 61 business data customers through MEI's fiber network. MEI is headquartered at 123 W. Orchard Street, Box 127, Delton, Michigan 49046. MEI is a wholly owned subsidiary of Barry County Services Company ("BCSC"), a C-corporation incorporated under the laws of the State of Michigan in 1991. BCSC has approximately 250 shareholders, 30 employees, and a formally elected Board of Directors. MEI's sister corporation, Barry County Telephone Company ("BCTC") is a rural incumbent local exchange carrier ("ILEC") that was founded in 1917 and has been the provider of telephone and Internet services to Delton and surrounding communities including but not limited

to Barry Township, Dowling, Hope Township, Johnstown Township, Pine Lake, and Lake Doster Michigan. BCTC provides service to 13 community facilities and 10 anchor institutions including several Township fire departments, Township halls, schools, and libraries. BCTC currently holds ETC authority in Michigan. MEI is well qualified to be designated as an ETC. MEI holds core competencies in the design, deployment, and operation of high-capacity access solutions that provide private, residential and enterprise broadband services. MEI has operated as an Internet Service Provider ("ISP") since 1992. In 2014, MEI became certificated as a competitive local exchange carrier ("CLEC") in order to expand its service area to communities that were not well served by other providers. Since that time, MEI has proactively built fiber networks to serve Michigan communities and to provide economic opportunity through access to affordable and competitive broadband speeds. MEI's VoIP and POTS voice calls are provisioned and routed using Ribbon Communications C 15 communications switch. All SIP trunks terminate on a Ribbon Q 10 session boarder controller for security and session management before routing to the C 15 switch. See attached **Exhibit A**. Voice announcements, custom calling features, and voice mail are provided by Innovative Systems APMAX applications server. MEI has been able to connect businesses and residential communities with fiber optic and wireless technologies. Currently MEI provides an option for rural subscribers to access to a modern broadband Internet experience throughout Hastings, Gun Lake, Nashville, Oshtemo Township, Rutland Township, Shelbyville, Wayland Township, and Vermontville, Michigan. MEI provides services to 16 community facilities and 14 anchor institutions including but not limited to Barry County Sheriff, Barry County e911, The County of Barry (County seat offices), Hastings Public Library, Village of Nashville Municipal offices, Public Works, and Public Safety, Village of Vermontville Municipal offices and public works facilities, St. Rose of Lima School as well as providing service to many rural businesses. MEI has also recently been designated as a winning bidder by the Federal Communication Commission ("FCC") Office of Economics and Analytics and the Wireline Competition Bureau in the Rural

Digital Opportunity Fund ("RDOF") Phase 1 Reverse Auction (Auction 904) whereby the FCC is offering support for successful bidders to expand their networks to provide high speed fixed broadband service to rural homes and small businesses that lack it. MEI was assigned \$479,789.10 over a ten-year period to serve one hundred and seventy-five locations with Gigabit, low latency service. MEI Telecom is currently in compliance with the RDOF requirements and is meeting all fiber/broadband build-out deadlines. Attached as **Exhibit B** is a copy of the Census block identification numbers where the support was awarded and where MEI is required to seek a High Cost and Lifeline ETC designation ("RDOF Area") and the new requested areas.

MEI is also seeking High Cost and Lifeline ETC designation in an area where MEI has recently been awarded funding under the Department of Agriculture's Rural Utility Service Reconnect Program ("Reconnect Area").

MEI is led by a well-qualified management team that has many decades of experience developing, deploying, and operating telecom infrastructure. MEI is also financially well qualified to be designated as a High-Cost ETC and to provide Lifeline services pursuant to 47 C.F.R. § 54.202 (a)(4) as evidenced by the audited financial statements in our previous application.

III. MEI MEETS THE APPLICABLE REQUIREMENTS FOR ETC DESIGNATION

1. The Provision of Voice Grade Services

MEI acknowledges that, in accordance with the requirements of 47 C.F.R. § 54.101 (a) & (b), it will provide voice grade access to the public switched network or its functional equivalent. The voice grade service to be provided will utilize Voice over the Internet Protocol technology over its own fiber facilities in order to provision voice-equivalent service.

2. Local Usage

MEI will offer local usage plans with unlimited local service (with minutes of use for local service provided at no additional charge to end users). MEI will also offer broadband plans to meet the needs of customers that desire to purchase broadband only.

3. Toll Limitation Services

MEI will offer toll limitation services to qualifying low-income consumers.

4. Access to Emergency Services

MEI will provide access to the emergency services provided by local government or other public safety organizations, such as 911 and enhanced 911, to the extent the local government in an eligible carrier's service area has implemented 911 or enhanced 911 systems.

5. The Provision of Lifeline Services

MEI acknowledges that with Commission approval MEI will be eligible in all cases to claim reimbursement for Lifeline customers served and that, as a licensed basic local exchange carrier in the State of Michigan, MEI is required to offer the Lifeline discount to eligible customers regardless of federal reimbursement in compliance with Section 316 of the Michigan Telecommunications Act.

IV. ETC Qualifications

MEI provides the following information in response to the current Commission ETC Order for ETC applicants.

1. Certification Regarding Service Requirements.

Though this Application, MEI certifies that it will comply with the service requirements applicable to the support that it receives.

2. MEI will Advertise and Publicize the Availability of Lifeline Services.

MEI will broadly advertise the availability of Lifeline and its discounted rates to those that qualify in media of general distribution in compliance with 47 C.F.R. § 54.201(d)(2) and § 54.405(c). Attached as **Exhibit C** is a sample of the Lifeline advertising.

Information about MEI's Lifeline services, as well as all MEI's service offerings are available on MEI's website at <https://mei.net/lifeline/>. Information about the Lifeline application process is available at <https://mei.net/fine-print/>. A link to the Michigan Public Service Commission's Lifeline hotline will be posted on the company's website upon ETC Lifeline approval.

The combination of advertising and online information about Lifeline should be sufficient to reach those likely to qualify for Lifeline in compliance with 47 C.F.R. § 54.405(d).

3. Functionality in Emergency Situations.

MEI retains the ability to remain functional in emergency situations, including maintaining a reasonable amount of back-up power to ensure functionality without an external power source, the ability to reroute traffic around damaged facilities, and the capability of managing traffic spikes resulting from emergency situations. MEI has significant experience with emergency preparedness and is well prepared to respond to emergency situations. MEI has appropriate Disaster Recovery Plans in place to respond to emergency situations. MEI's fixed wireless network has reasonable amounts of back-up power and the ability to reroute traffic around damaged facilities and manage traffic spikes resulting from emergency situations. MEI's fiber optic network is supported by uninterruptible power supply facilities including 8 hours of battery backup. Fixed standby generators along with portable generators are used to maintain network and service up time for extended commercial power outage situations. MEI utilize numerous monitoring and management tools to respond to any service outages and to pro-actively anticipate any bottlenecks or developing network issues.

MEI intends to continually upgrade its capabilities (tools and training) to troubleshoot the network, to the subscribers and upstream.

4. Consumer Protection and Service Quality Standards.

MEI will satisfy applicable consumer protection and service quality standards, including complying with 47 C.F.R. § 54.202 (g) and all applicable state and consumer protection and service quality standards. As an operating CLEC in Michigan, MEI already is subject to Michigan's consumer protection and service quality requirements and MEI's customers will receive the service quality and consumer benefits of those protections. MEI will be responsible, managerially, and legally, for handling and responding to any customer issue.

MEI follows all applicable federal and state monitoring and reporting service quality metrics. MEI has implemented consumer protection measures to protect private customer information including the adoption and implementation of a Customer Proprietary Network Information ("CPNI") Policy that is consistent with federal regulations. MEI has also made all required annual CPNI certifications. MEI's customer service number is (269) 623-9005 which is available for complaints and service issues. That number is available on MEI's website at: <https://mei.net/customer-support/>.

To the extent that customers receive wireless services, those services will be fixed wireless services, not mobile wireless. Therefore, some of the provisions of the Cellular Telecommunications and Internet Association's ("CTIA") Consumer Code for Wireless Services ("CTIA Code") are not applicable to MEI. MEI will comply with those portions of the CTIA Code which are applicable to fixed wireless services.

5. Tribal Lands.

MEI is not seeking designation as an ETC Lifeline for any part of Tribal Lands. MEI's service area does not include any tribal lands.

V. Conclusion

Applicant submits that the information contained herein demonstrates that MEI meets the requirements for a Lifeline ETC designation in the selected areas and the expansion of MEI's broadband service offering in the state of Michigan will serve the public interest.

WHEREFORE, MEI respectfully requests that the Commission promptly grant this Application as soon as possible.

Respectfully submitted,

David Stoll

MEI Telecom, Inc.

123 W. Orchard

Delton, Michigan 49046

dstoll@mei.net

269-623-9971

Dated November 30, 2022

STATE OF MICHIGAN

§

COUNTY OF BARRY

§

§

VERIFICATION

I, David Stoll, am the General Manager and CEO of MEI Telecom, Inc. (the "Company"), that I am authorized to make this Verification on behalf of the Company, that the foregoing Application was prepared under my direction and supervision; and that I certify or declare under penalty of perjury under the laws of the State of Michigan that the foregoing is true and correct to the best of my knowledge, information, and belief.

MEI commits to provide the services and functionalities required for designation as a High-Cost and Lifeline ETC in the areas described in the Application. MEI will use any federal High-Cost support funds that it receives to only provide, construct, upgrade and maintain the facilities and services for which the support is intended. Lifeline support funds will be used to apply the benefit to those qualified subscribers.

David Stoll, General Manager & CEO

Sworn and subscribed before me this 30 day of November 2022.

Exhibit A

Call Flow Diagram

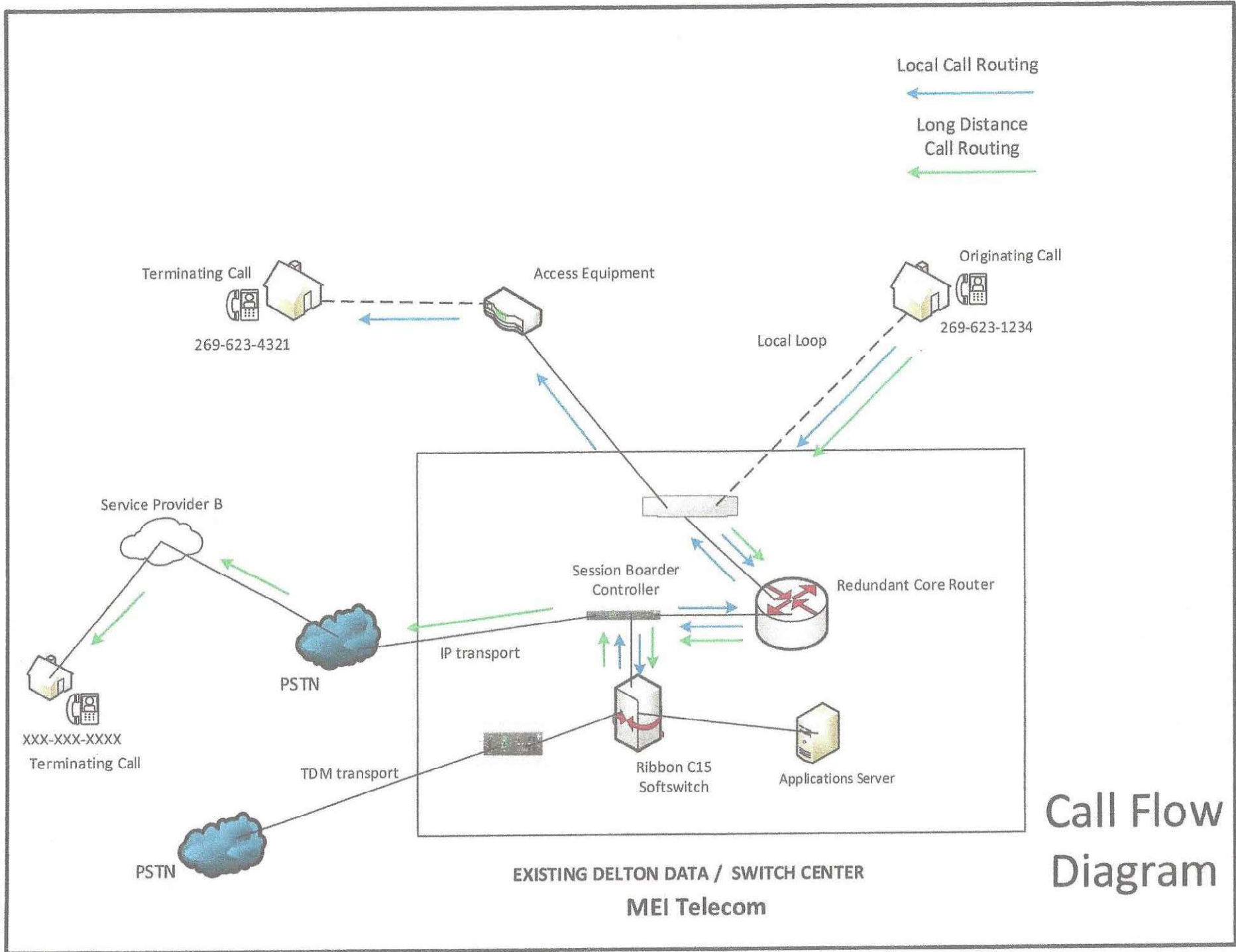

Call Flow Diagram

Exhibit B

**Current Areas and New Requested
Areas**

260150101001007
260150101001017
260150101001018
260150101001019
260150101001021
260150101001023
260150101001025
260150101001027
260150101001029
260150101001030
260150101001032
260150101001037
260150101001038
260150101001039
260150101001041
260150101001043
260150101001044
260150101001045
260150101002028
260150101002029
260150101002030
260150101002031
260150101003009
260150101003012
260150101003013
260150101003014
260150101003017
260150101003018
260150101003031
260150101003032
260150101003033
260150101003034
260150101003035
260150101003036
260150101003037
260150101003038
260150101003039
260150101003040
260150101003041

260150101003042
260150101003043
260150101003044
260150101003099
260150101003100
260150101003101
260150101003104
260150101004001
260150101004002
260150101004003
260150101004004
260150101004005
260150101004006
260150101004007
260150101004008
260150101004009
260150101004010
260150101004011
260150101004012
260150101004013
260150101004014
260150101004015
260150101004016
260150101004017
260150101004018
260150101004019
260150101004020
260150101004021
260150101004022
260150101004023
260150101004024
260150101004025
260150101004026
260150101004027
260150101004028
260150101004029
260150101004030
260150101004031
260150101004032
260150101004033
260150101004034
260150101004035
260150101004036

260150101004037
260150101004038
260150101004039
260150101004040
260150101004041
260150101004042
260150101004043
260150101004044
260150101004046
260150101004047
260150101004048
260150101004049
260150101004050
260150101004051
260150101004052
260150102001017
260150102001029
260150102001030
260150102001031
260150102001032
260150102001034
260150102001036
260150102001040
260150102001042
260150102001043
260150102001051
260150102001053
260150102001056
260150102001060
260150102001062
260150102001063
260150102001065
260150102001068
260150102001069
260150102001071
260150102001072
260150102001074
260150102001078
260150102001079
260150102001080
260150102001081
260150102001082
260150102001083

260150102001084
260150102001085
260150102001086
260150102001088
260150102001089
260150102001090
260150102001091
260150102001092
260150102001093
260150102001094
260150102001095
260150102001096
260150102001097
260150102001098
260150102001099
260150102001100
260150102001101
260150102001102
260150102001103
260150102002001
260150102002010
260150102002015
260150102002021
260150102002030
260150102002031
260150102002032
260150102002037
260150102002045
260150102002047
260150102002049
260150102002052
260150102002053
260150102002054
260150102002059
260150102003012
260150102003017
260150102003020
260150102003022
260150102003024
260150102003025
260150102003027
260150102003028
260150102003029

260150102003032
260150102003033
260150102003035
260150102003036
260150102003037
260150102003038
260150102003039
260150102003041
260150102003042
260150102003043
260150102003044
260150102003045
260150103002000
260150103002006
260150103002008
260150103004036
260150103004037
260150103004064
260150103004073
260150103004074
260150103004075
260150103004076
260150103004077
260150103004078
260150103004079
260150103004084
260150104011001
260150104021028
260150104021029
260150104021030
260150104021031
260150104021034
260150104021035
260150104021041
260150104021043
260150104022001
260150104022003
260150104022010
260150104022011
260150104022012
260150104022013
260150104022014
260150104022015

260150104022016
260150104022017
260150104022020
260150104022021
260150104022022
260150104022025
260150104022026
260150104022027
260150104022028
260150104022029
260150104022031
260150104022032
260150104022033
260150104022034
260150104022035
260150104022037
260150104022038
260150104022039
260150104022040
260150104022041
260150104022042
260150104022043
260150104022064
260150104022065
260150104022066
260150104022068
260150104022069
260150104022071
260150104022073
260150104022074
260150104022075
260150104022076
260150104022078
260150104022079
260150104022080
260150104022081
260150105003051
260150105003062
260150106001000
260150106001001
260150106001004
260150106001006
260150106001007

260150106001008
260150106001012
260150106001032
260150106001034
260150106001035
260150106001036
260150106001037
260150106001038
260150106001046
260150106001047
260150106002050
260150107001000
260150107001001
260150107001002
260150107001003
260150107001004
260150107001005
260150107001006
260150107001008
260150107001009
260150107001010
260150107001011
260150107001012
260150107001046
260150107001047
260150107002000
260150107002001
260150107002002
260150107002003
260150107002004
260150107002005
260150107002006
260150107002007
260150107002008
260150107002009
260150107002010
260150107002011
260150107002012
260150107002013
260150107002014
260150107002015
260150107002016
260150107002017

260150107002020
260150107002021
260150107002022
260150107002023
260150107002024
260150107002025
260150107002026
260150107002028
260150107002029
260150107002030
260150107002031
260150107002032
260150107002033
260150107002034
260150107002035
260150107002036
260150107002038
260150107002039
260150107002040
260150107002041
260150107002043
260150107002047
260150107002048
260150107002053
260150107002054
260150107002055
260150107002056
260150107002072
260150107002073
260150107002074
260150107002075
260150107002076
260150107002077
260150108001014
260150108001017
260150108001018
260150108001034
260150108001038
260150108001079
260150113001001
260150113001002
260150113001006
260150113001034

260150113001035
260150113001039
260150113001040
260150113001042
260150113002042
260150113002043
260150113003000
260150113003001
260150113003002
260150113003014
260150113003019
260150113005015
260150113005029
260150113006000
260150113006002
260150113006003
260150113006004
260150113006005
260150113006006
260150113006007
260150113006008
260150113006009
260150113006011
260150113006012
260150113006013
260150113006014
260150113006016
260150113006017
260150113006019
260150113006020
260150113006021
260150113006026
260150113006027
260150113006028
260150113006029
260150113006030
260150113006031
260150113006033
260150113006034
260150113006035
260150113006036
260150113006037
260150113006038

260150113006039
260150113006040
260150113006041
260150113006042
260150113006043
260150113006044
260150113006045
260150113006046
260150113006047
260150113006048
260150113006049
260150113006050
260150113006051
260150113006052
260150113006053
260150113006054
260150113006055
260150113006056
260150113006057
260150113006058
260150113006059
260150113006060
260150113006061
260150113006062
260150113006063
260150113006064
260150113006065
260150113006066
260150113006067
260150113006068
260150113006069
260150113006070
260150113006071
260150113006072
260150114001001
260150114001002
260150114001003
260150114001004
260150114001005
260150114001006
260150114001007
260150114001008
260150114001014

260150114001025
260150114001026
260150114001027
260150114001028
260150114001029
260150114001030
260150114001031
260150114001033
260150114001034
260150114001035
260150114001036
260150114001038
260150114001040
260150114001041
260150114001044
260150114001047
260150114001051
260150114002001
260150114002004
260150114002006
260150114002008
260150114002009
260150114002010
260150114002012
260150114002016
260150114002017
260150114002018
260150114002020
260150114002023
260150114002024
260150114002027
260150114002028
260150114002029
260150114002030
260150114002033
260150114002037
260150114002038
260150114002049
260150114002051
260150114002052
260150114002053
260150114003004
260150114003005

260150114003007
260150114003009
260150114003010
260150114003011
260150114003013
260150114003019
260150114003023
260150114003024
260150114003025
260150114003028
260150114003029
260150114003030
260150114003047
260150114003051
260150114004017
260150114004024
260150114005009
260150114005010
260150114005011
260150114005012
260150114005015
260150114005016
260150114005017
260150114005021
260150114005023
260150114005024
260150114005025
260150114005027
260150114005028
260150114005029
260150114005030
260150114005031
260150114005032
260150114005033
260150114005034
260150114005035

260150105003051
260150105003062
260150106001007
260150106001008
260150106001012
260150106001036
260150106001038
260150107001000
260150107001001
260150107001004
260150107001006
260150107001009
260150107001013
260150107002022
260150107002025
260150107002034
260150107002036
260150107002043
260150107002053
260150107002054
260150107002055

New Requested Area

260150105003
260150106001
260150107001

Exhibit C

Sample Lifeline Advertising



Lifeline

What is Lifeline?

Lifeline is a federal program that lowers the monthly cost of phone and Internet for qualifying customers.

You can get one Lifeline discount (phone or Internet, but not both) per household, not per person, and a household can get a Lifeline discount from only one provider.

Do I qualify?

You may qualify for a Lifeline discount based on:

1. Your income - You may be eligible for a Lifeline discount if your income is 135% or less than the federal poverty guidelines.

- OR -

2. Participation by you or someone else in your household in one of the following federal assistance programs:

- Supplemental Nutrition Assistance Program (SNAP), formerly known as Food Stamps
- Medicaid
- Supplemental Security Income (SSI)
- Federal Public Housing Assistance (FPHA)
- Veterans Pension and Survivors Benefit
- Tribal Programs (and live on federally-recognized Tribal lands)

Qualifying customers will need to recertify every year to maintain their Lifeline discount. You'll need to do this within 60 days of notification, or you'll lose your Lifeline discount.

How do I apply?

Please apply online via the National Verifier website:

www.lifelinesupport.org/national-verifier

You can also download and print a copy of the application or request one from our office.

Once you have applied and been approved by the National Verifier eligible customers will receive a discount applied to their bill.

Barry County Telephone Company & MEI Telecom, Inc.

107 North Grove • Delton, MI 49046-0127

Customer Service 269-623-2311 • Fax 269-623-8033